

Uninterruptible Power Supply

COVER

HS 105 / HS 205 / HS305 / HS505

100-500 kVA

User Manual



THE POWER IS ON

The content of this document is protected by copyright and may not be reproduced without prior permission.
Subject to modification of design and specifications without prior notice.

©Copyright 2017
COMEX S.A.
All rights reserved.

Table of Contents

1.	Precautions	1
2.	Installation procedure.....	3
2.1.	Introduction.....	3
2.2.	Preliminary review	3
2.3.	Location	4
2.3.1	UPS room	4
2.3.2	Battery room.....	4
2.3.3	Storage.....	4
2.4.	Unpacking, checking and setting up	4
2.4.1	Unpacking and checking	5
2.4.2	Setting up.....	6
2.5.	UPS design.....	9
2.6.	Diemensions and weight of UPS	11
2.7.	Service space	13
2.8.	Connecting wires to UPS	14
2.9.	Electrical installation – general requirements	17
2.9.1	Power input of UPS	17
2.9.2	Battery circuit protection.....	17
2.10.	Power cords and terminal strips.....	18
2.10.1	Connecting wires	19
2.11	Communication cables	21
2.11.1	Dry Contact - sensor for detecting battery temperature and environment	22
2.11.2	REPO switch port	23
2.11.3	External bypass interface.....	24
2.11.4	Interface to BCB battery switch	24
2.11.5	Output signal - Low battery	24
2.11.6	Output signal - event warning	25
2.11.7	Output signal - no power supply.....	26
2.11.8	Port USB, RS-232 and RS-485.....	26
2.11.9	SNMP slot and parallel card slot.....	26
3	UPS operating modes.....	27
3.1	Introduction.....	27
3.2	Principle of operation.....	27
3.3	Bypass module	28
3.4	Modes of operation.....	28
3.4.1	Normal mode	28
3.4.2	Battery mode	28
3.4.3	Automatic restart.....	29
3.4.4	Bypass mode	29
3.4.5	Service bypass mode.....	29
3.4.6	Economical (ECO).....	29
3.4.7	Frequency converter mode	29



4	User manual	30
4.4	Procedures to start the power supply	30
4.4.1	Start up the UPS from full shutdown	30
4.4.2	Starting the UPS from the battery	31
4.2	Procedures for switching the power supply between modes	32
4.2.1	Switching from normal to battery mode	32
4.2.2	Switching from Normal to Bypass mode	32
4.2.3	Switching from Bypass mode to normal operation	32
4.2.4	Switching from Normal to Service bypass mode	33
4.2.5	Switching from Bypass mode to normal operation	33
4.3	Complete power off procedure	34
4.4	Emergency shutdown with EPO	34
4.5	Battery test.....	34
5	LCD panel support.....	36
5.1	Introduction	36
5.1.1	LED indicators.	37
5.1.2	Audible alarm.....	37
5.1.3	Function keys	38
5.2	LCD touch screen display	38
5.2.1	Main menu	39
5.2.2	Cabinet	37
5.2.3	Module.....	41
5.2.4	Setting	43
5.2.5	Log.....	45
5.2.6	Operate	37
5.2.7	Scope.....	38



1. Precautions



This user manual contains the necessary information regarding the installation and use of the COVER series HS power supplies.

Before beginning installation and use, you are asked to read this manual carefully. The UPS must be installed and configured by an authorized service center of the manufacturer or distributor. In the case of installation by people without the required experience, there is a risk of users being exposed to health or life. Persons not authorized to install may damage the power supply, which in this case is not subject to warranty conditions.

 COMPLETE STANDARDS
The appliance complies with CE-Directives 73/23 and 93/68 (low voltage safety) as well as 89/336 (EMC) and the following standards: *IEC62040-1-1 *IEC/EN62040-2 EMC CLASS C3 *IEC62040-3

  WARNING - Large leakage current
Connecting the protective conductor (PE) is essential and must be done before connecting the remaining working cables (power supply, receiving, battery). Grounding should be carried out in accordance with prevailing standards and practical on-site knowledge. The leakage current exceeds 3.5 mA and is less than 1000 mA. When selecting RCCB or RCD devices for immediate operation, the transient and fixed leakage currents that may occur during commissioning must be considered. Automatic residual current circuit breakers (RCCBs) that are sensitive to DC unidirectional (Class A) pulses and are insensitive to transient current pulses shall be selected. Also note that the RCCB or RCD device will conduct the leakage current of the receiver.

  Operation
There is dangerous voltage in the UPS housing. The risk of contact with such voltage is minimized as the live parts are behind the enclosure. Additional internal protection guards ensure that the device is protected in accordance with IP20 protection class. Normal operation of the device, taking into account recommended operating procedures, does not pose any risk to personnel. All maintenance and service procedures require access to the inside of the machine and should only be carried out by trained personnel.

  Battery high voltage > 400 Vdc
All maintenance and installation work may be performed by a properly trained service technician. After connecting the battery the voltage at their terminals exceeds 400 Vdc and is potentially fatal.

Battery manufacturers give detailed precautions that must be followed when working on or near large battery packs. Such measures must always be strictly observed. Special attention should be paid to recommendations regarding local environmental conditions and the provision of protective clothing, first-aid and fire-fighting equipment.

2. Installation procedure

This chapter is dedicated to the installation method, how to mount and wiring the UPS.

2.1. Introduction

This chapter describes the basic requirements for the positioning and wiring of the power supply. This description is a step-by-step installation guide, which provides a number of guidelines for how to guide your service during assembly.

 Warning - Installation may only be carried out by an authorized service center
<ol style="list-style-type: none">1. Do not connect electrical appliances to the power supply before confirming that the power supply is properly connected and configured.2. The UPS should be installed by qualified technicians in accordance with the guidelines in this chapter. <p>Do not perform any electrical work that interferes with the electrical installation before and after the UPS while the UPS is operating. Damage arising from this title (eg phase sequence replacement) is not covered by the warranty.</p>

 Warning: dangerous batteries
<p>Special precautions must be observed when working with batteries connected to the power supply. After connecting the battery, the voltage at the terminals exceeds 400 Vdc and is potentially fatal.</p> <p>It is recommended to use protective eyewear to protect your eyes from accidental electric arc. In addition, it is recommended that:</p> <ul style="list-style-type: none">▪ Remove the rings, watches and all metal objects.▪ Use only tools with insulated handles.▪ If the battery leaks or the battery other way is damaged, replace it. Damaged batteries should be stored in a container resistant to sulfuric acid and disposed of in accordance with local regulations.▪ If the electrolyte comes in the contact with the skin, the contaminated area should be washed immediately with water.

2.2. Preliminary review

Please perform the following checks before installation:

- Check visually whether the equipment supplied, ie the UPS and the batteries, have not been damaged as a result of their transport. Any damage should be reported immediately to the supplier.
- Verify the compliance of the supplied equipment with the installation requirements. The power of the power supply is described on the label each time.

2.3. Location

2.3.1 UPS room

The UPS is designed for indoor installation. The device should be in a clean, ventilated environment in order to maintain the ambient temperature within the required specifications. The UPS provides forced convection cooling through internal fans. Cold air enters the unit through the ventilation openings located in the front of the enclosure and is blown out by the grills in the rear of the enclosure. Do not block the ventilation openings.

Depending on the conditions of the room, the ventilation openings of the power supply should be regularly cleaned, eg with a vacuum cleaner. Ventilation will ensure efficient cooling and longer service life.

Note: The UPS should be installed on a stable and non-flammable surface.

2.3.2 Battery room

In the final charging process, the batteries emit some oxygen and hydrogen into the environment and therefore require constant fresh air access to the room in which they are located. Safety requirements for battery compartments are described in PN-EN 50272-2.

The battery temperature should be stable as it is the main parameter that affects battery life and capacity. The optimal operating temperature of the battery is 15-25 ° C. It is recommended to maintain a nominal temperature of 20 ° C.

Working at higher temperatures shortens the battery life and reduces the battery capacity in the lower battery. Each increase in battery operating temperature by another 8 ° C, reduces the service life by 50%.

Keep batteries away from heat sources and hot air outlets.

When installing batteries outside the UPS, use the battery circuit as close as possible to the battery. The connecting cables for the batteries and UPS should be as short as possible.

2.3.3 Storage

If the device is not installed and needs to be stored, protect it from excessive humidity and high temperatures. Keep batteries in a dry and cool place with good ventilation. The most suitable storage temperature for batteries is 20-25 ° C.

2.4. Unpacking, checking and setting up

Before unpacking, carefully inspect the package supplied or damage during transportation. After removing from the package, check that the equipment does not show signs of damage. If there are any damages, please notify the supplier immediately.

2.4.1 Unpacking and checking

The power supply is supplied in a wooden housing. The following is how to open the casing.

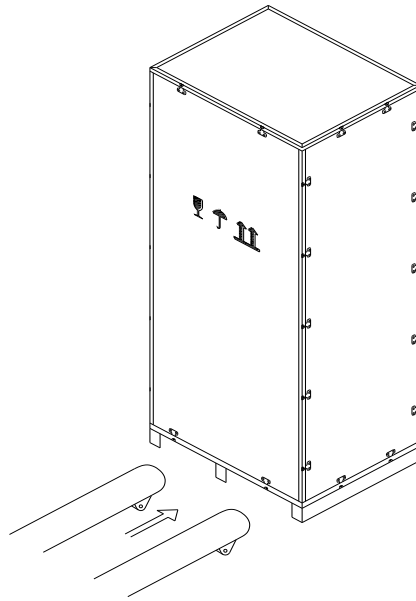

Figure 2-1 The way of opening

First open the upper housing cover, then remove the side walls of the housing. Be careful not to scratch the power supply case. See Figure 2-2.

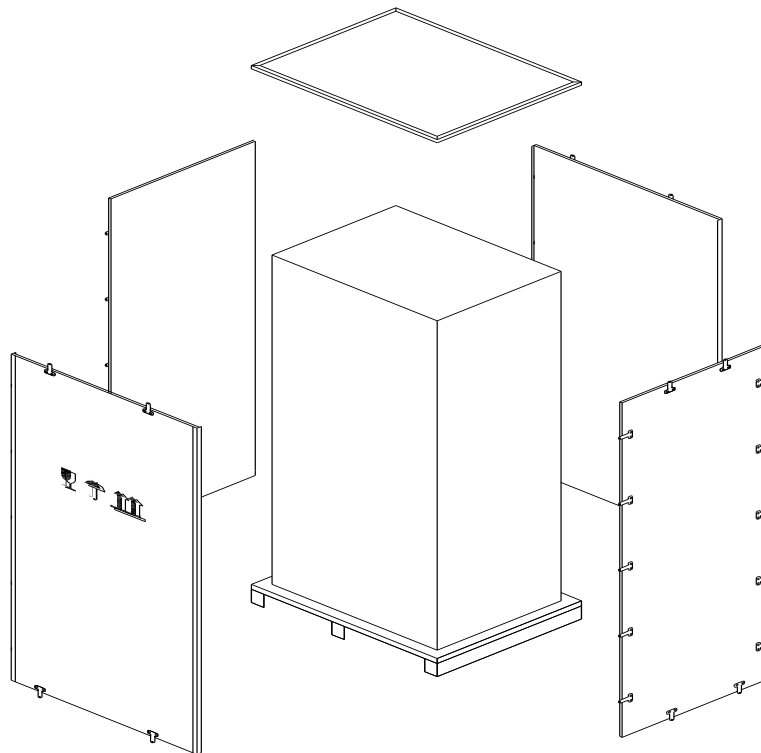

Figure 2-2 Disassembly of the housing

Remove lateral protection. Unpacked UPS looks like the figure below.

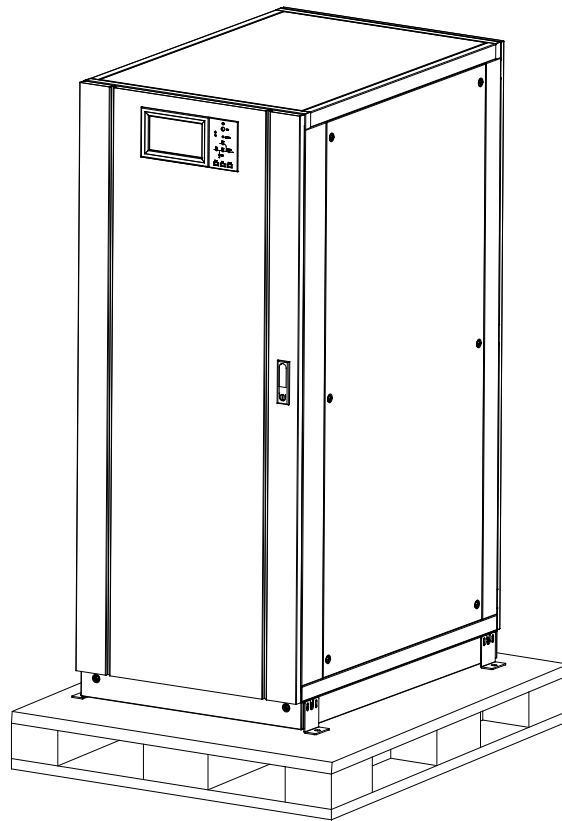

Figure 2-3 View of the power supply after removing the housing

Tip: Remove the screws connecting the UPS power casing to the wooden pallet, and then place the UPS at the installation point. Disassembly should be carried out with care not to scratch the case.

Verify that the supplied equipment is properly labeled on the back of the UPS door. The label contains basic information about model, power, etc.

Note: Disposal materials should be disposed of in accordance with local environmental requirements.

2.4.2 Setting up

To ensure that the power supply is properly mounted, consider the following:

1. The UPS and battery compartment that will work with it should be large enough to accommodate the various components of the system. The dimensions and weight of the UPS are described in the further part of this manual. The dimensions and weight of the racks / cabinets with batteries depend on the chosen system's autonomy and therefore the quantity and capacity of the battery. This information should be obtained directly from the distributor.
2. Due to the large dimensions and weight of the equipment, it is recommended that the room provided on the UPS and batteries be located at level "0". Such location allows the pallet truck to be transported directly to the place of foundation. Any other location that

requires vertical transport eg stairs, and requires consultation with the distributor's technical department.

3. The floor / ceiling strength in which the UPS and batteries are placed must take into account the maximum pressure of the equipment.
4. The floor on which the devices are located must be stable, level and flat.
5. The room in which the battery cells will be located due to the possibility of generating small amounts of hydrogen must be equipped with a ventilation system suitable for the capacity of installed batteries in accordance with the requirements of EN 50272-2 / 2007.
6. Unless there is no other place for UPS room, in addition to its UPS and battery mounts, shall provide for the installation of a power switchboard, a switchboard, an external bypass switch and a battery disconnecter, as well as an air conditioning system.

In order to prolong the life of the device, a suitable installation site should be provided to ensure that:

1. Ease of connection to the installation
2. Sufficient space to handle
3. Ventilation / air conditioning for proper cooling of the power supply
4. Protection against gases that may cause corrosion
5. Protection against excessive moisture and heat sources
6. Protection against dust and other contaminants
7. Proper fire protection
8. The working temperature should be between 20 and 25 ° C. At such temperatures, the batteries show optimum performance.

Each UPS casing is equipped with castors for maneuvering the UPS at the installation site for proper setup. After mounting the UPS, lock the UPS by removing the stabilizing screws. The spacing and dimensions of the UPS base are shown in the figures below:

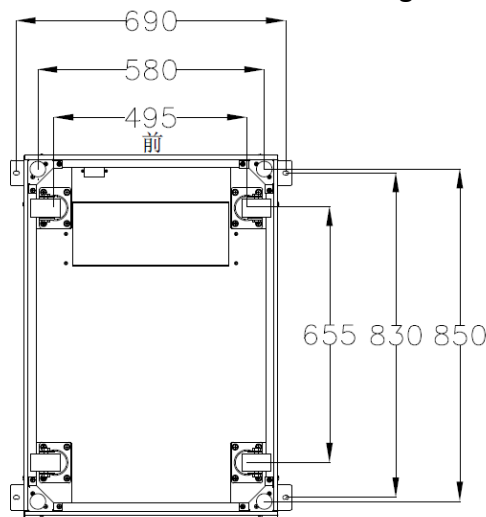

Figure 2-4 Basic view UPS COVER HS 105, HS 205 and HS 305

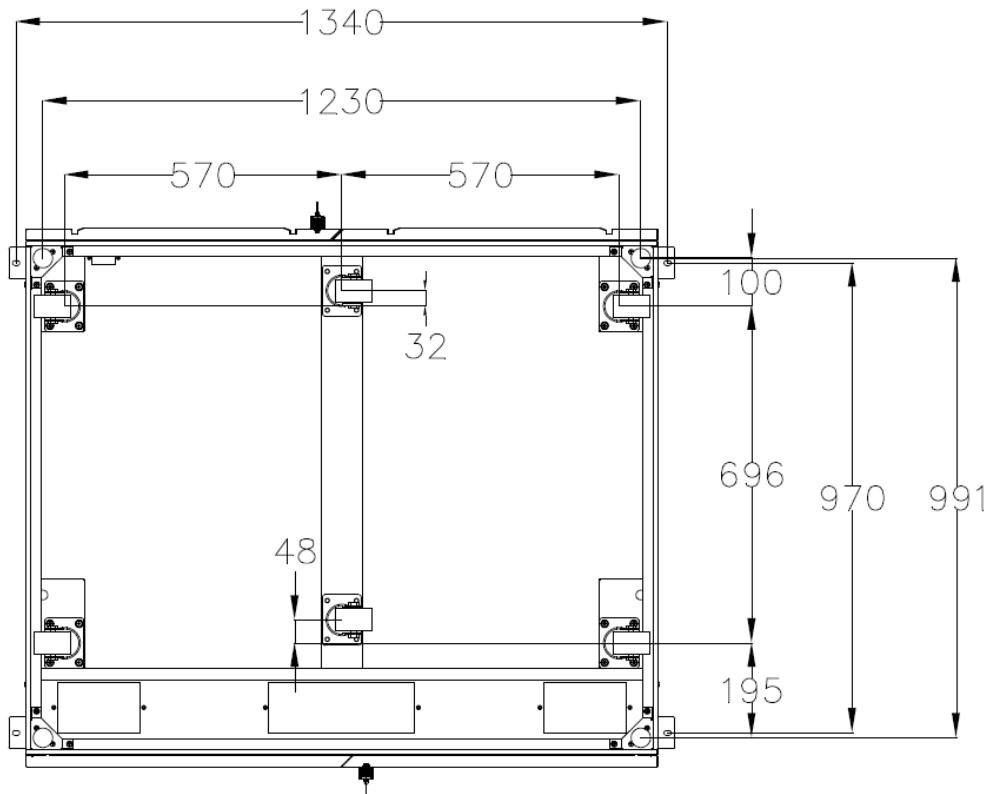

Figure 2-5 Basic view UPS COVER HS 505

2.5. UPS design

The appearance of each UPS model is shown in the figures below:

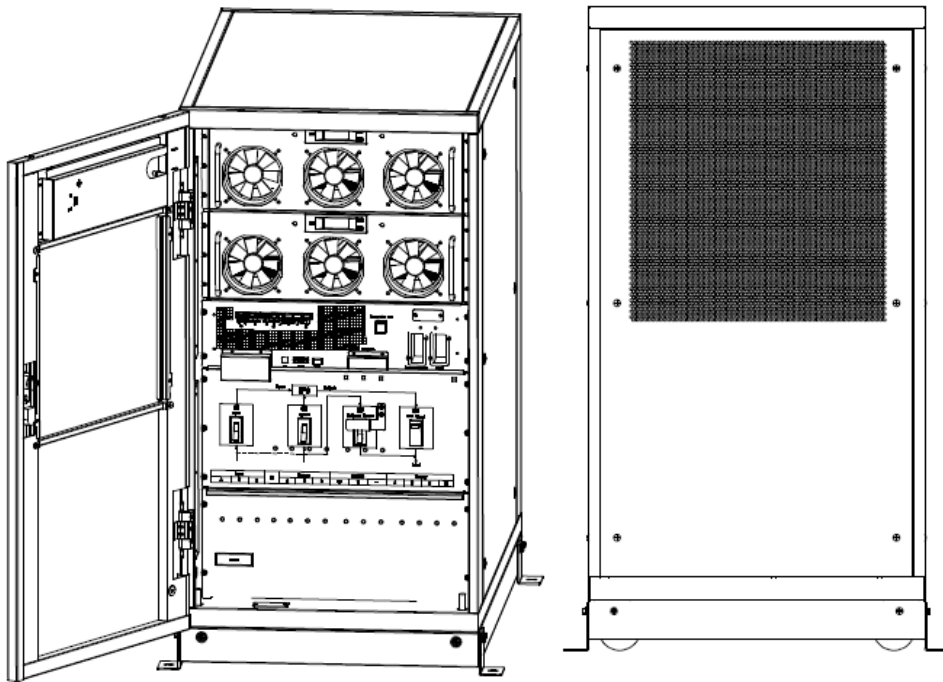

Figure 2-6 Front / rear view of the power supply UPS HS 105/100 KVA

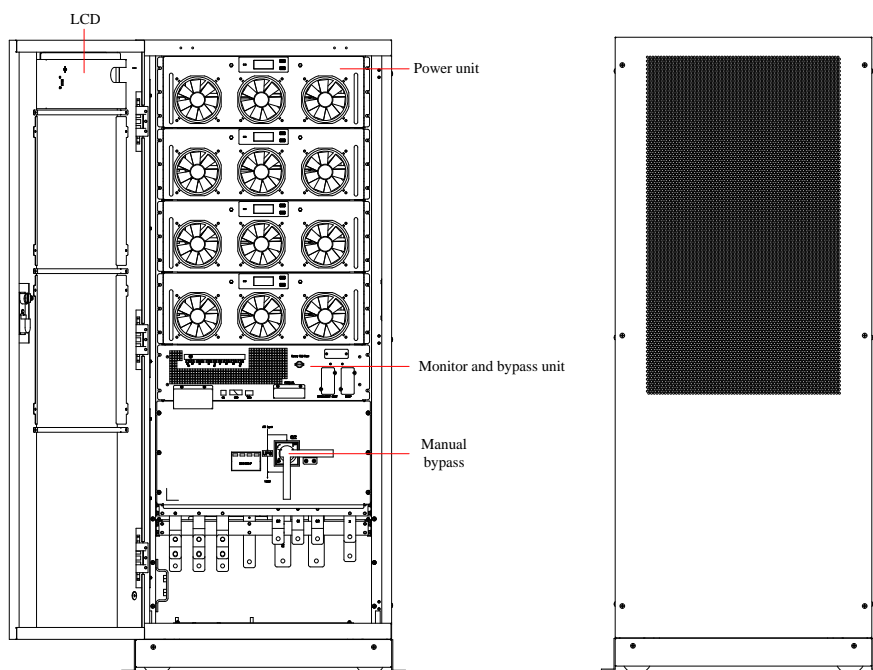

Figure 2-7 Front / rear view of the power supply UPS HS 205/150-200KVA

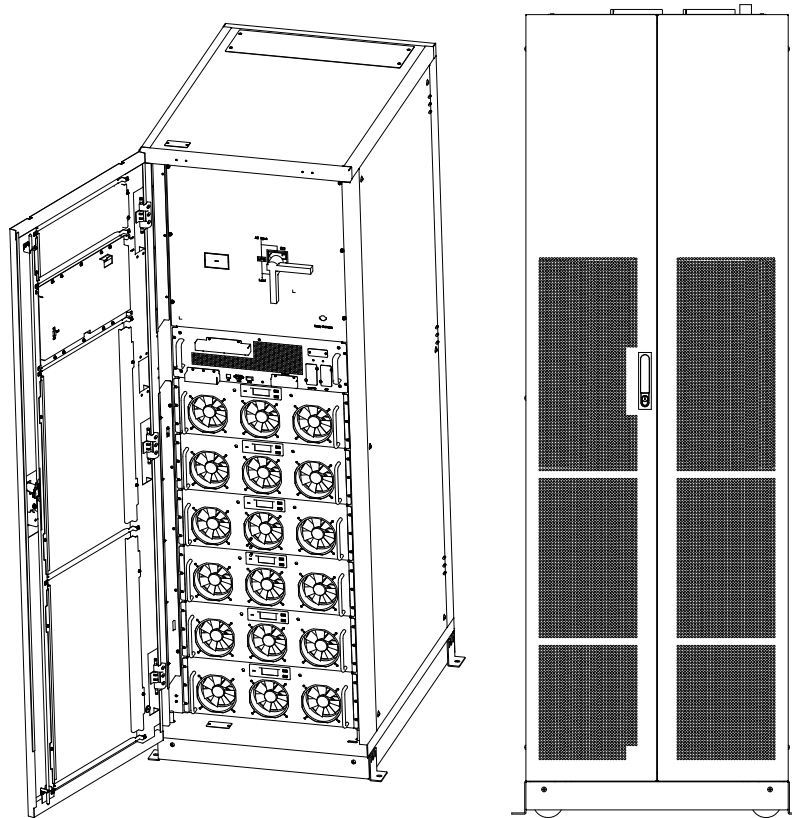

Figure 2-8 Front / rear view of the power supply UPS HS 305/250-300kVA

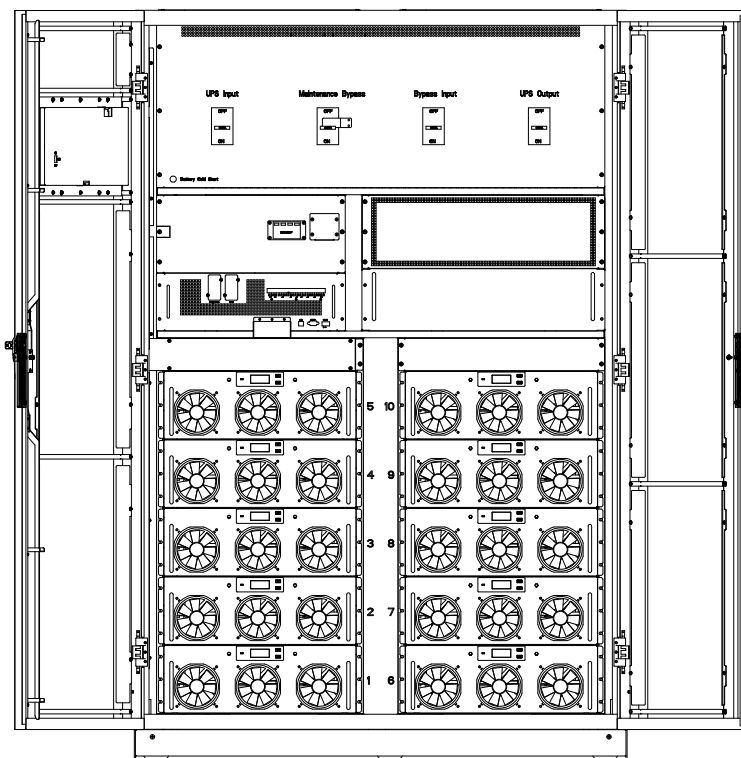

Figure 2-9 Front view of the power supply HS 505/350-500kVA

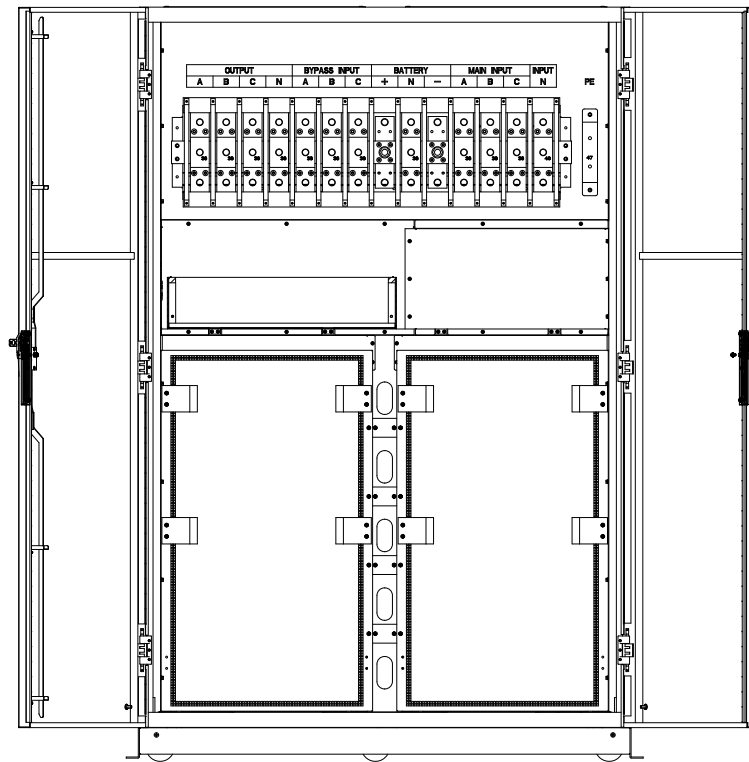

Figure 2-10 Rear view of the power supply UPS HS 505/350-500kVA

2.6. Dimensions and weight of UPS

The following figures show the casing dimensions of each UPS model.

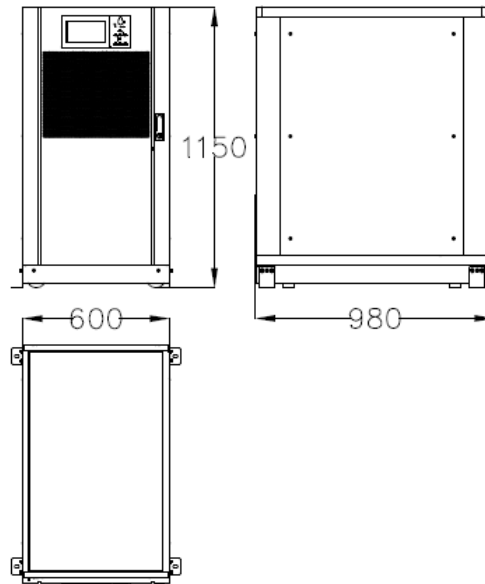

Figure 2-7 Dimensions of the power supply casing UPS HS 105/100 KVA

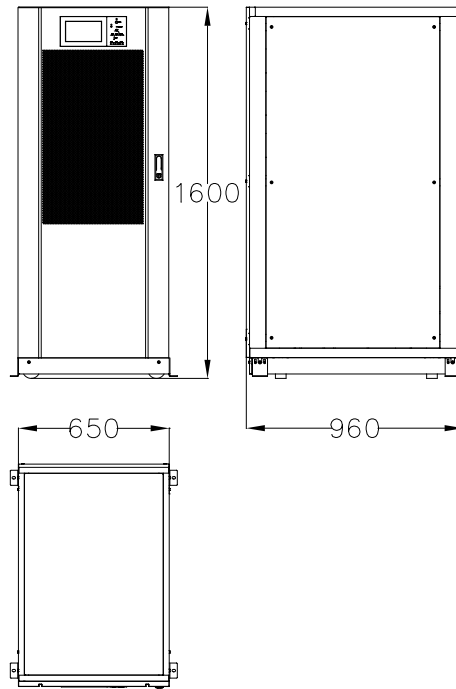

Figure 2-82 Dimensions of the power supply casing UPS HS 205/150-200kVA

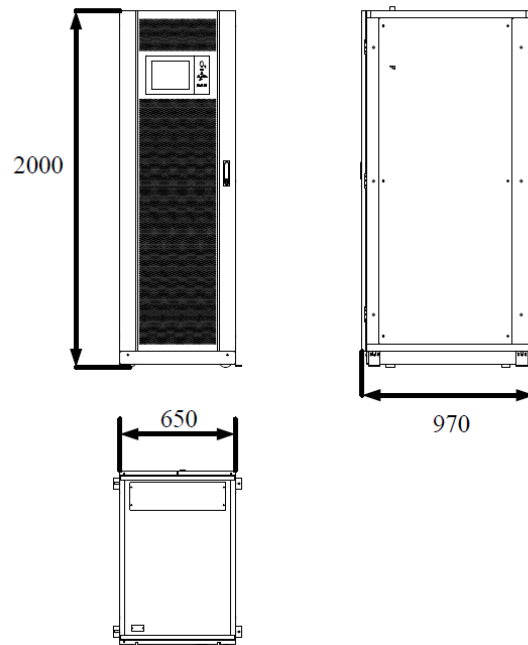

Figure 2-93 Dimensions of the power supply casing UPS HS 305/250-300kVA

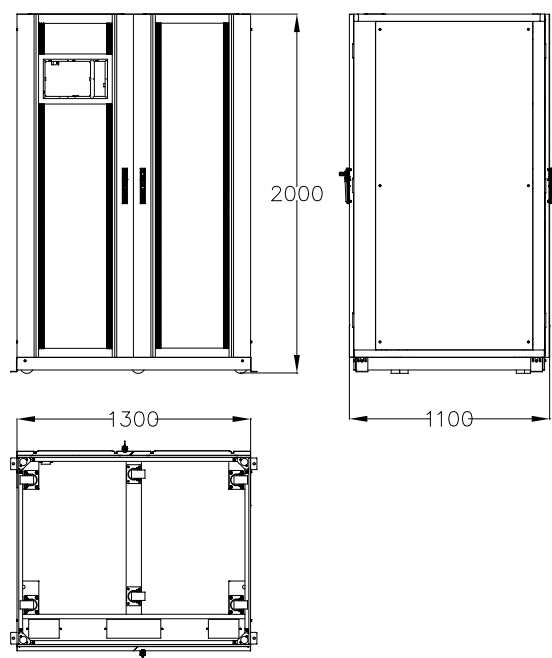

Figure 2-104 Dimensions of the power supply casing UPS HS 505/350-500kVA

The table below contains the mass of the above devices:

Power UPS	Weight
HS 105/100kVA	210 kg
HS 205/150kVA	305 kg
HS 205/200kVA	350 kg
HS 305/250kVA	445 kg
HS 305/300kVA	490 kg
HS 505/350kVA	765 kg
HS 505/400kVA	810 kg
HS 505/450kVA	855 kg
HS 505/500kVA	900 kg

2.7. Service space

On the side walls of the power supply unit there are no ventilation openings, therefore there is no need for ventilation space on the side. For access to the device on each side, it is recommended to keep min. 50 cm service area.

It is necessary to provide adequate space from the front of the power supply for easy operation and the ability to draw cold air from the environment. Recommended 80 cm front space.

Due to the required access to the back of the power supply and free air discharge and circulation, the recommended back space of the power supply is a minimum of 50 cm.

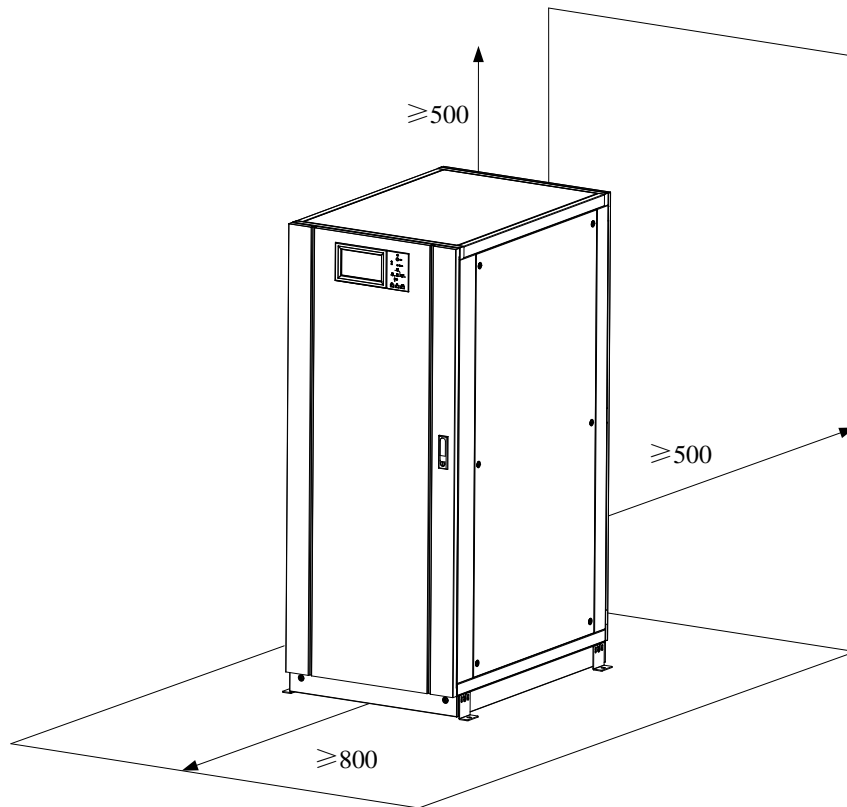

2.8. Connecting wires to UPS

Depending on the casing model, different approaches to power supply and cords are possible. For the HS 205, a cable approach is provided from the bottom of the housing as in the example in the figure below.

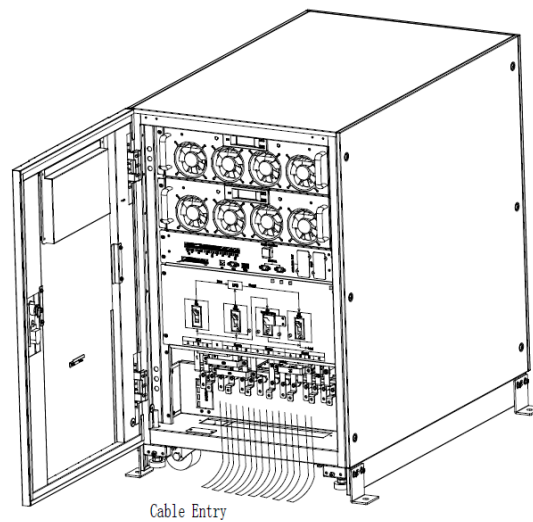

Figure 2-15 Cable approach in UPS HS 105- 205

The housing of the HS 305 provides a top-down approach to the UPS as shown below:

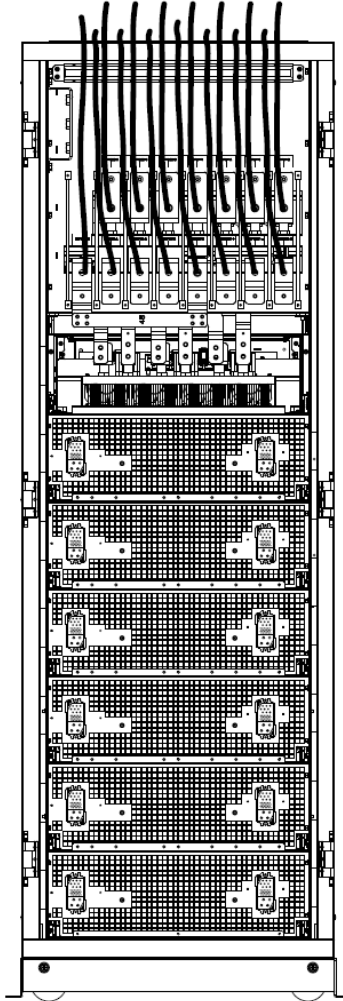

Figure 2-16 Cable approach in UPS HS 305

The housing of the HS 505 power supply allows both bottom and top cable approaches, as shown in the figure below:

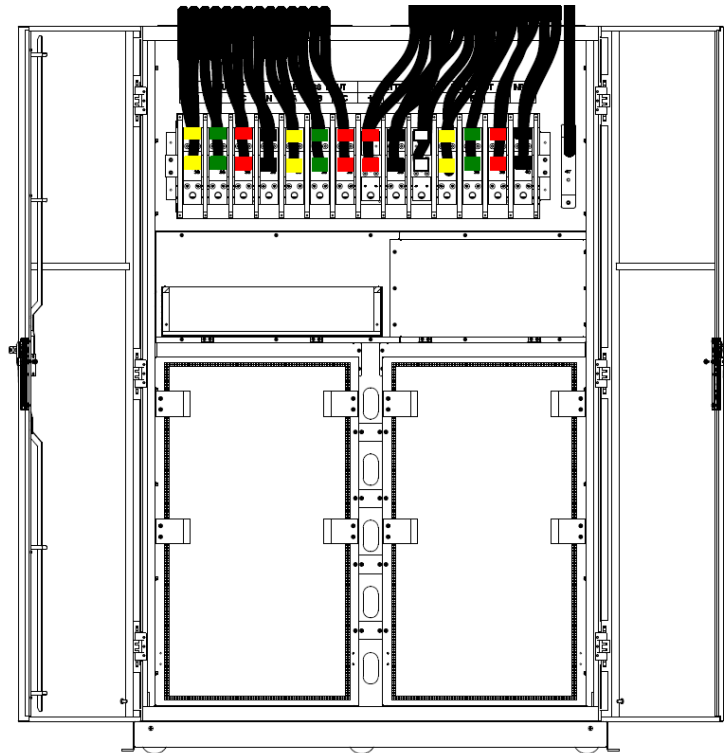

Figure 2-17 Cable approach from top in UPS HS 505

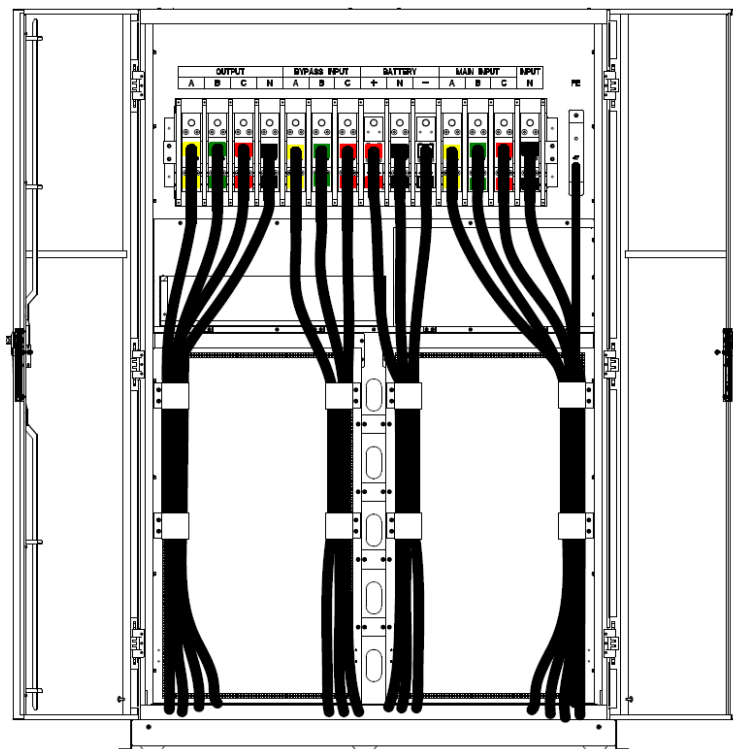

Figure 2-11 Cable approach from bottom in UPS HS 505

2.9. Electrical installation – general requirements

For safety reasons, it is necessary to install appropriate protections in the form of surge suppressors or other protective devices in the UPS distribution board. This chapter provides general practical information for installation by qualified electricians. In addition, staff with the appropriate knowledge and authority should be aware of the standards and standards applicable to the local market for type and cross-section of wires, their arrangement and their load capacity. It is recommended to use flexible hoses type LgY or OpD. Detailed installation instructions are available from your UPS distributor.

2.9.1 Power input of UPS

The UPS should be powered from an electrical switchgear equipped with a suitable security device selected for maximum system power and flexible hoses with appropriate current carrying capacity selected for the protection used.

If you need to install RCDs on the UPS power supply, keep in mind that these units should:

- be sensitive to unidirectional DC current pulses (Class A)
- not be sensitive to transient current impulses
- adjustable sensitivity range 0.3 - 1A.

The RCD must be sensitive to unidirectional DC current pulses and insensitive to transient current pulses as shown below:

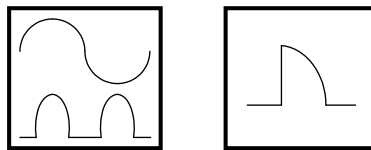

Figure 2-19 Circuit breaker designation RCD

2.9.2 Battery circuit protection

The battery required for proper operation of the power supply consists of a standard of 40 12 V batteries connected in series. 3 wire installation with center neutral is required, taken from a central connection between battery 20 and 21. The battery circuit must be protected with a suitable fuse that is rated for the power of the UPS.

A detailed drawing of the battery installation is shown below:

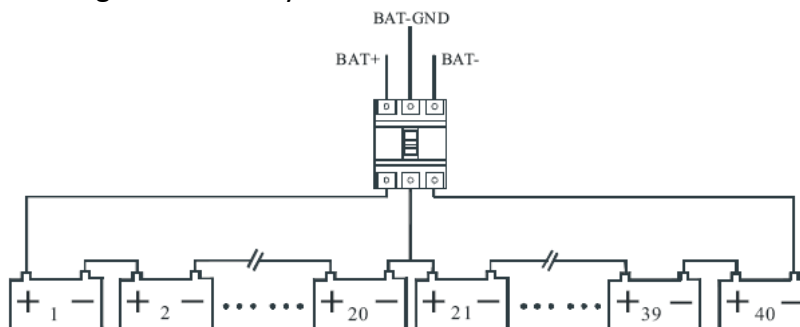

Figure 2-12 Diagram of serial connection of 40 batteries with central neutral point

2.10. Power cords and terminal strips

The main factors that affect the selection of wires are the supply voltage, current, room temperature and cable installation conditions.

The power supply cables of the system must be selected in accordance with the applicable regulations at the site and comply with the following description:

- The input power cords of the power supply must match the maximum input current and maximum charging current shown in the table below, including the power rating of the power supply and the AC input voltage.
- Output and bypass cables must be matched to the rated output currents given in the table, including the power rating of the power supply and the AC output voltage.
- Battery cables must be matched to the discharge current of the battery at the voltage at the end of discharge indicated in the table, taking into account the power rating of the power supply.
- The terminal block is equipped with screw connections. Select the appropriate cable clamp and use the appropriate tightening torque given in the table below.

Table 2-1 Table of power supply currents for 400Vac and 40 batteries

Power UPS	Rectifier	Bypass/ Output	Battery	Type of conection	Tightening torque
HS 105/100kVA	152A	145A	208A	M6, M8	4,9Nm, 13 Nm
HS 205/150kVA	227A	216A	313A	M10	15Nm
HS 205/200kVA	303A	289A	417A	M10	15Nm
HS 305/250kVA	380A	362A	521A	M12	28Nm
HS 305/300kVA	455A	433A	626A	M12	28Nm
HS 505/350kVA	533A	507A	729A	M16	96Nm
HS 505/400kVA	607A	578A	833A	M16	96Nm
HS 505/450kVA	685A	652A	938A	M16	96Nm
HS 505/500kVA	759A	723A	1042A	M16	96Nm





Warning

The power supply needs to be connected to the PE protective conductor. Incorrect connection of the protective conductor may cause malfunction of EMI filters and result in electric shock or fire.

- The terminal strip for connecting power / receiving cables is located on the front for the HS 205 housing and on the back of the power supply unit for HS 305 and HS 505.

2.10.1 Connecting wires

 Warning
<p>BEFORE PERFORMING THE POWER SUPPLY, PLEASE RELY TO THE LOCATION AND OPERATION OF EXTERNAL SWITCHES WHICH MAY CONNECT THE POWER SUPPLY / OUTPUT SUPPLY WITH THE NETWORK DISTRIBUTION CHECK THAT THE ABOVE POWER SOURCES ARE ELECTRICALLY DISCONNECTED AND TO MAKE NECESSARY WARNING WRITTEN TO BE UNINDED THAT THEY ARE INCIDENTALLY ACTUALLY ONCE THAT THE UPS SHOULD NOT SHOW THEM ON THE CABLE AT THE UPS.</p>
 Attention
<p>The operations described in this section should be performed by a suitably trained service team. The contractor is responsible for preparing the power supply and the power supply to the power supply.</p>

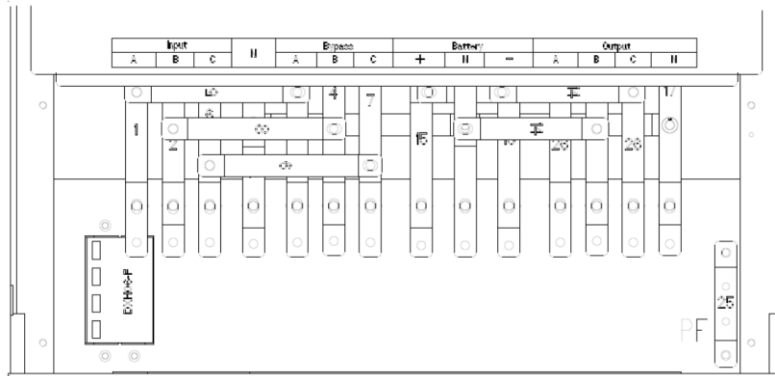

Figure 2-13 View of the terminal block for connecting cables HS 105

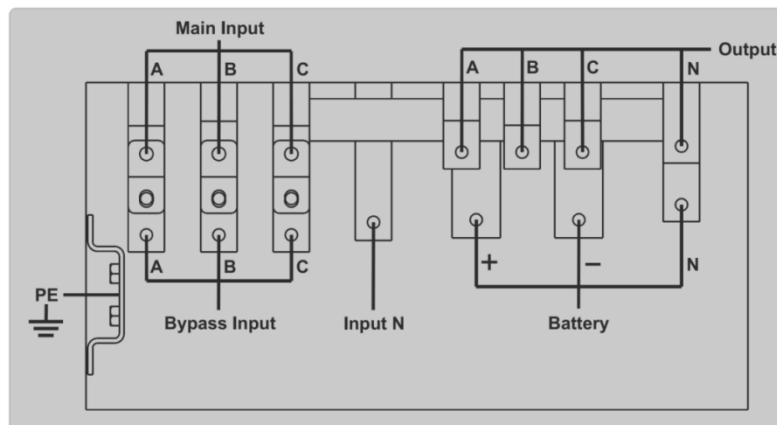

Figure 2-14 View of the terminal block for connecting cables HS 205

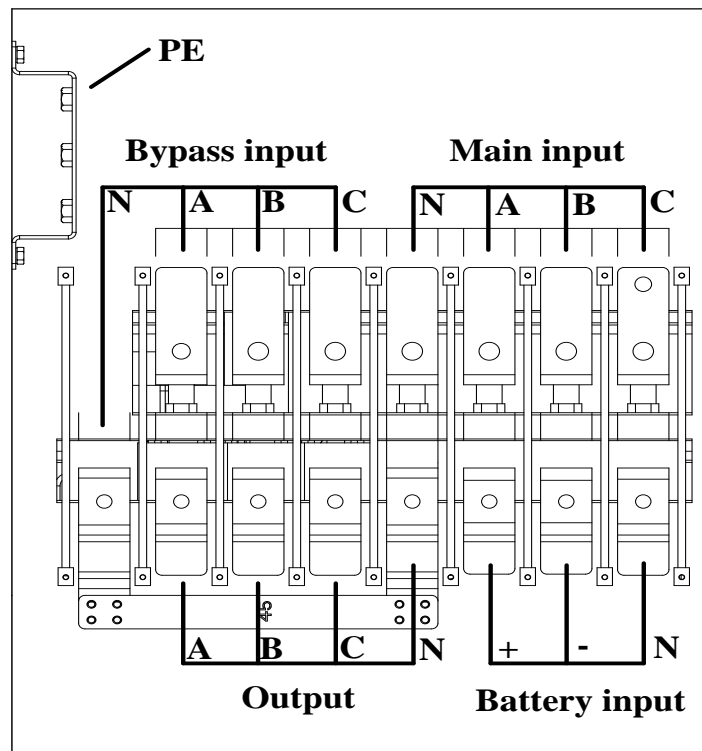

Figure 2-23 View of terminal block for connection of HS 305 wires.

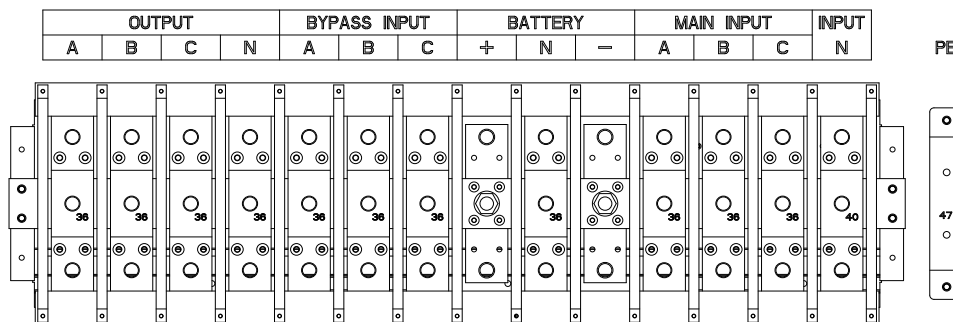



Figure 2-24 View of terminal block for connection of HS 505 wires

After properly aligning and securing the power supply from moving, connect the wires with the following rules:

1. Check that the power supply is completely disconnected from the external power source and that the service bypass switch on the power supply is open. Make sure these power sources are electrically isolated and arrange the necessary warning signs to prevent them from being accidentally switched on.
2. Open the front or back door of the power supply and remove the cover to gain access to the power supply.
3. Connect the earth ground wire. The connection must comply with local regulations and standards.
4. When connecting a monorail (common rectifier and bypass input), connect the power supply wires to the main input, the output wires are the output terminals. Check the correct sequence (rotation) of the phases. When connecting two paths with separate rectifier and

bypass supply power, the bridges connecting the main input and the Bypass input must be removed.

5. Connect the power cords between the UPS and the battery disconnect switch. Check correct polarity.

	Warning - Dangerous voltage on battery terminals
<p>Make sure that the polarity of the battery is correctly connected. Battery positive terminal for positive terminal (BATTERY +) on UPS, negative battery terminal for battery terminal (BATTERY-) on UPS, neutral terminal for neutral terminal (N) on UPS.</p>	

6. Install the protective cover.

2.11 Communication cables

As shown in the figure below, the communication interface of the power supply unit is located behind the power supply door and consists of a contact interface (Dry Contact J2-J10), USB communication interface, RS-232, RS-485, parallel port and two expansion card slots, SNMP. There is also a button called “cold start”, which allows the battery to run from the battery even if the power supply is not in the professional network.

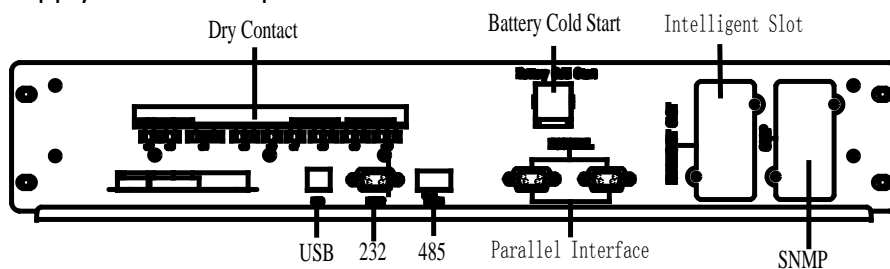

Figure 2-25 Communication interface of power supply unit HS 205 or HS 305.

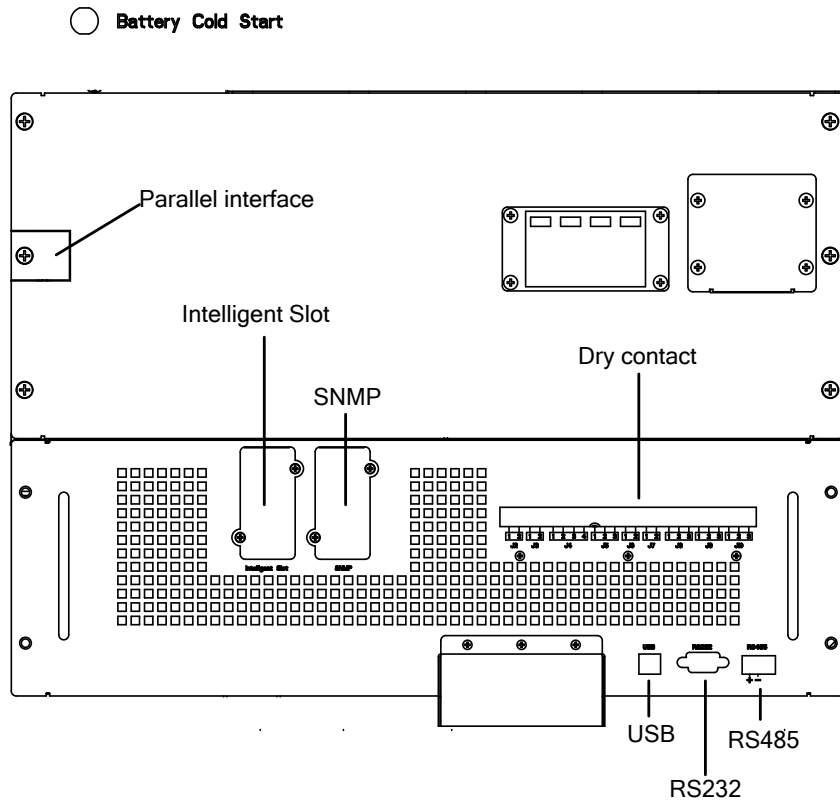

Figure 2-26 Communication interface of power supply unit HS 505.

The wires connected to the DryContact interface must be potential-free and separate from AC conductors. Wires should be double insulated with a cross section of 0.5-1.5 mm² and their maximum length should not exceed 50m.

2.11.1 Dry Contact - sensor for detecting battery temperature and environment

The Dry Contact J2 and J3 input signals are used to detect the temperature of the battery and the environment at the sensor site. The battery temperature sensor is used to compensate the temperature of the battery charging voltage. The interface and connection description are shown below.

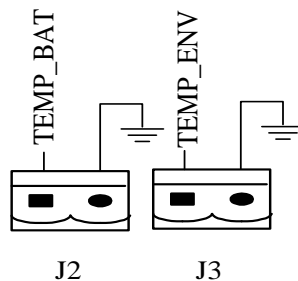

Figure 2-27 View of the interface DryContact J2 and J3

Table 2-2 Description of DryContact J2 and J3 interface terminals

Pin	Description	Purpose
J2.1	TEMP_BAT	Battery temperature detection
J2.2	GND	Ground
J3.1	TEMP_ENV	Environmental temperature detection
J3.2	GND	Ground

Note: Use suitable temperature sensors for proper detection ($R_{25} = 5 \text{ Ohm}$, $B_{25} / 50 = 3275$). Please confirm the compliance of the supplier at the time of placing the order.

2.11.2 REPO switch port

The UPS has a REPO interface to remotely shutdown the UPS in case of an emergency (eg fire). The function can be activated by pressing the key on the front panel of the power supply or remotely using the remote REPO switch.

Use the J4 connector to connect the remote REPO. During normal operation, NC and + 24V short-circuits are required. Activation of the EPO signal occurs when the NC signal is + 24V open or short circuit of the NO and + 24V pins. The interface and connection description are shown below.

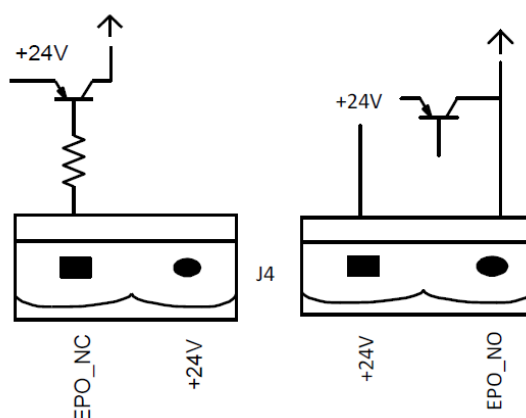

Figure 2-158 Interface REPO

Table 2-3 Description of the REPO interface terminals

Pin	Description	Purpose
J4.1	EPO_NC	EPO is activated when disconnected from J4.2
J4.2	+ 24V	+24V, voltage to connect with NC
J4.3	+ 24V	+24V, voltage to connect with NO
J4.4	EPO_NO	EPO is activated when connected from J4.2

Use an external potential-free REPO circuit breaker using a normally closed (NC) or normally open (NO) contact.

If you do not use the remote REPO, pin J4.1 must be connected to J4.2 and pin J4.3 disconnected from J4.4.

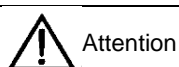

Attention

1. Użycie wyłącznika EPO powoduje zatrzymanie pracy prostownika, falownika oraz Bypassu, oraz odłączenie napięcia na wyjściu zasilacza.
2. Standardowo pin J4.1 i J4.2 są połączone ze sobą w momencie dostarczania sprzętu.

2.11.3 External bypass interface

Input connector J5 is used for communication with external bypass. Pins J5.1 and J5.2 are open (NO) while the UPS is operating normally (bypass bypass in UPS position). Bypassing the external bypass to the BYPASS position closes the 5.1 and 5.2 (NC) pins.

The UPS automatically returns to normal operation when the bypass is switched to the UPS position.

Table 2-4 Description of interface terminals

Pin	Description	Purpose
J5.1	EXT Bypass	Signaling work bypass external
J5.2	EXT Bypass	Signaling work bypass external
J5.3	n/a	n/a

2.11.4 Interface to BCB battery switch

J6 and J7 connectors are used in conjunction with the optional BCB battery circuit breaker. The interface and connection description are shown below.

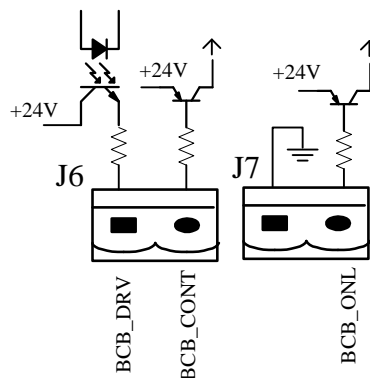

Figure 2-169 Interface BCB

Table 2-5 Description of BCB interface terminals

Pin	Opis	Przeznaczenie
J6.1	BCB_DRV	Output signal for triggering (disconnecting) of the battery disconnecter in case of EPO trip or eg deep discharge of battery. Generated + 18V, 20mA signal
J6.2	BCB_CONT	Input signal indicating the position of the battery switch On / Off.
J7.1	GND	Ground
J7.2	BCB_ONL	Input signal indicating the connection to the UPS, BCB. Signal shortage with J7.1 tells UPS to install the BCB.

2.11.5 Output signal - Low battery

The Dry Contact J8 connector is a low battery indication. If the battery voltage is lower than the value set, then the J8 output will receive this information. There are two types of battery status signal - NO (normally open contact) or NC (normally closed contact) - change of contact position means low battery voltage. Below the interface description and description of the connection.

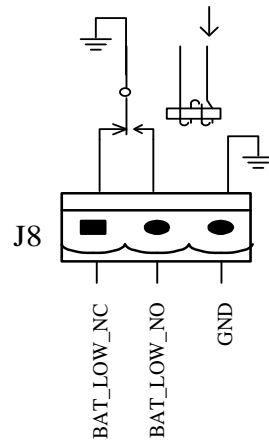

Figure 2-30 Interface Bat_Low

Table 2-6 Description of interface terminals

Pin	Description	Purpose
J8.1	BAT_LOW_NC	Relay indicating low battery voltage - normally closed (J8.1 and J8.3). Opening it means a warning about low battery voltage.
J8.2	BAT_LOW_NO	Relay indicating low battery voltage - normally open (J8.2 and J8.3). Its closure means a warning of low battery voltage.
J8.3	GND	Common pin for NO / NC signals.

2.11.6 Output signal - event warning

Connector J9 is a signal that one or more warnings appear on the UPS. Occurrence of at least one alarm on the UPS causes the relay contacts to close or open. Below the interface description and description of the connection.

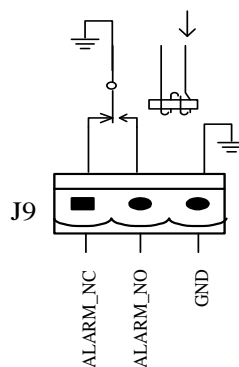

Figure 2-31 Alarm interface

Table 2-7 Description of alarm interface terminals

Pin	Description	Purpose
J9.1	ALARM_NC	Relay indicating the occurrence of an alarm - normally closed (J9.1 and J9.3). Its opening indicates an alarm.
J9.2	ALARM_NO	Alarm relay indicating normally occurring alarm (J9.2 and J9.3). Its closure indicates an alarm.
J9.3	GND	Common pin for NO / NC signals.

2.11.7 Output signal - no power supply

Connector J10 is a signal indicating power failure at the UPS input. Below the interface description and description of the connection.

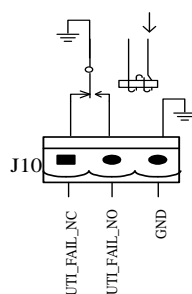

Figure 2-32 Interface for power failure

Table 2-8 Description of the interface power supply interface terminals

Pin	Opis	Przeznaczenie
J10.1	UTI_FAIL_NC	Relay indicating power failure - normally closed (J10.1 and J10.3). Its opening means the disappearance.
J10.2	UTI_FAIL_NO	Relay indicating power failure - normally open (J10.2 and J10.3). Its closure means the disappearance.
J10.3	GND	Common pin for NO / NC signals.

2.11.8 Port USB, RS-232 and RS-485

USB, RS-232 and RS-485 ports are used to communicate the power supply to the monitoring software and to configure the power supply by the manufacturer's authorized service provider.

2.11.9 SNMP slot and parallel card slot.

The SNMP Slot is used to optionally connect a remote communication card via Web / SNMP.

UPS also allows parallel operation when the UPS is upgraded to a parallel card, which is mounted in a special slot designed for mounting this type of card.

3 UPS operating modes

This chapter describes the basic operating modes of the UPS, battery management and protection.

 <p>Warning: There are dangerous voltages - mains and batteries inside the UPS</p> <p>There are no user serviceable parts inside the UPS. Only the manufacturer's authorized service provider has the opportunity to open the UPS.</p>
--

3.1 Introduction

There are no user serviceable parts inside the UPS. Only the manufacturer's authorized service provider has the opportunity to open the UPS.

Achieving high quality parameters guarantees high frequency dual pulse width modulation (PWM), all controlled by digital signal processing (DSP), which ensures high reliability and ease of use.

3.2 Principle of operation

As shown in the figure below, the power supply from the professional network feeds the UPS. The rectifier transforms the AC voltage into DC. The constant voltage powers the inverter circuit, which reprograms the DC voltage to a stable AC voltage that is completely independent of the input voltage. In the absence of mains voltage, the inverter circuit is powered from the battery. In case of maintenance work, or in case of overload, overheat or other events on the UPS, a backup power supply is used. Bypass.

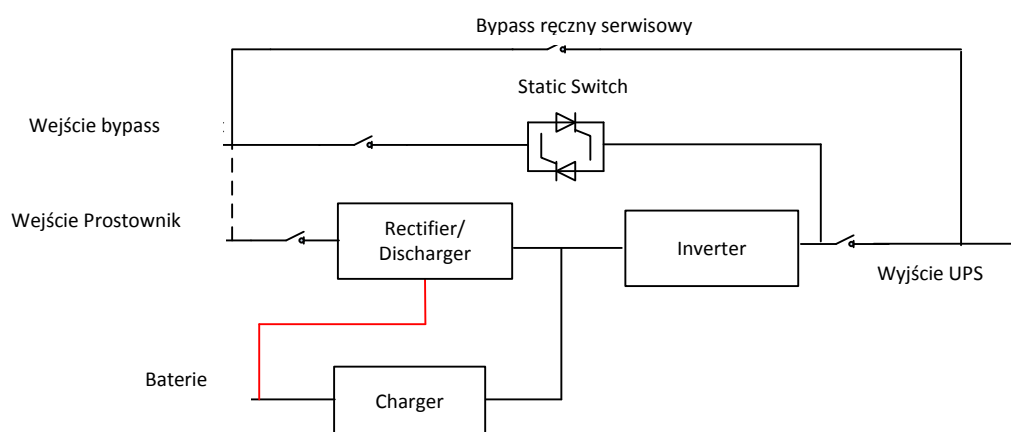

Figure 3-1 Block diagram of the power supply

3.3 Bypass module

Bypass is an electronic uninterruptible switch that supplies voltage to the inverter output or bypass circuit directly from the network. During normal operation, the receivers are powered directly from the inverter output, but if events such as overload, overheat or inverter failure occur, the load is automatically switched to the Bypass circuit.

To ensure uninterrupted switching between inverter operation and bypass operation, the inverter output must remain synchronized with the Bypass line voltage at all times. Synchronization is provided by the inverter voltage and frequency control system, which ensures synchronization of the frequency generated by the inverter to the Bypass circuit voltage, provided that the bypass voltage remains within the allowable tolerance range.

The UPS was additionally equipped with a service bypass system. The bypass is manually switched on when maintenance work is required on the UPS. Bypass Bypass can only be activated if the UPS is in Electronic Bypass mode.



When the UPS is in Bypass mode or Bypass Service mode, the connected receivers are not protected by power outages and network disruptions.

3.4 Modes of operation

The COVER series HS power supply is a dual power processor that allows you to operate in the following modes depending on your configuration:

- Normal mode(On Line)
- Battery mode
- Automatic restart
- Electronic bypass
- Service bypass (mechanical)
- Economical (ECO)
- Frequency converter
- Parallel mode

3.4.1 Normal mode

In normal operation, the output voltage from the UPS is generated by the inverter. Normal operation means that there is a voltage in the professional network with the appropriate parameters that feeds the power supply rectifier. Straight-up voltage is a source of power for the inverter circuit, which produces a guaranteed voltage with stable and fully independent input voltage parameters. In normal operation, rechargeable batteries are also charged.

3.4.2 Battery mode

In the event of a power failure in the professional network, the power supply inverter consumes the energy stored in the battery. During power failure in the network, the battery is switched to uninterruptible mode, which means that there is no power interruption from the point of

view of the power supply. Voltage return on the professional network automatically returns to normal mode, without the need to intervene.

Note: The UPS can also be started from the battery in the so-called mode. "Cold start", ie in the absence of basic power.]

3.4.3 Automatic restart

In case of prolonged power failure when the batteries are discharged after reaching the minimum voltage (EOD - End Off Discharge). The UPS is turned off.

The power supply can be configured for automatic restart after a service time delay set by the serviceman. The restart mode and any delay of the inverter can be programmed by the manufacturer's service.

During the programmed delay time of the inverter, the batteries are charged so that when the inverter is turned on, the receivers will be protected in the event of a power failure.

3.4.4 Bypass mode

In the case of overload of the power supply, overheating or other causes such as damage to the inverter in normal operation, the bypass switches are automatically and uninterruptedly switched to bypass.

3.4.5 Service bypass mode

The manual service bypass provided by the UPS allows you to carry out periodic maintenance work on the unit without de-energizing the power supply to the receivers. Service Bypass can be activated only when the UPS is in Bypass mode. Therefore, first switch the UPS to Bypass mode and then switch on the service bypass switch.

 Attention	When the UPS is in service bypass mode, the power modules and the LCD display do not work. Please note that there is a dangerous voltage on the terminal strip to which the power supply and the load are connected.
--	--

3.4.6 Economical (ECO)

In ECO mode, receivers are powered directly from the network through the Bypass reserve circuit, which improves the efficiency of the power supply and reduces energy consumption. In ECO mode, the preferred source of power is the bypass circuit until the voltage and frequency remain within acceptable tolerances. If the voltage parameters in the Bypass line are outside the set tolerance range, the inverter will automatically switch to the inverter output. Frequency switching is less than 15 ms for 50 Hz and 12.5 ms for 60 Hz.

3.4.7 Frequency converter mode

In the frequency converter mode, the power supply can be used to generate a fixed output frequency of 50 or 60 Hz. The input frequency tolerance range at which a stable output frequency can be generated is 40-70 Hz. Bypass mode is not available in this mode. In the event of power failure, the UPS generates the set frequency using the battery voltage.

4 User manual

This chapter provides detailed instructions on how to turn the power supply on and off, as well as switching between the modes described in the previous chapters.

All control keys and the LCD panel used to switch between the modes described below are described in detail in Chapter 5.

During the following procedures, acoustic signaling may occur. This alarm can be silenced at any time by pressing "Mute" on the LCD panel.

4.4 Procedures to start the power supply

4.4.1 Start up the UPS from full shutdown

Use the following procedure when starting the power supply from total shutdown.

 Attention	When the following procedure is performed, voltage appears on the output terminals of the power supply. If the power supply is connected to receivers, check that the power supply is safe. If the receivers are not ready to connect the power supply, make sure they are securely isolated from the UPS output.
--	---

The startup procedure for a dual power supply is as follows:

1. Close the UPS output switch (Q4) - for the HS 505 UPS only. For the HS 205 and HS 305 power supplies that have only a mechanical bypass disconnect switch, use an external power switch in the UPS power distribution board.

Close the bypass input switch (Q2) and then the rectifier (Q1) - for HS 505 only. The switching sequence is very important. For power supplies HS 205 and HS 305, equipped with a mechanical bypass switch only, use external power connectors in the UPS power switchboard.

The rectifier LED flashes during the start up of the rectifier. The LEDs on the UPS should look like the following table:

LED	State
Rec diode	Green flashing
Battery diode	Red
Bypass diode	Turn off
Inv diode	Turn off
Output diode	Turn off
State diode	Red

Running takes about 30 seconds, after which time the rectifier diode glows green. After the start-up and testing process, the bypass and start-up of the inverter are switched on. The LEDs on the UPS should look like the following table:

LED	State
Rec diode	Green
Battery diode	Red
Bypass diode	Green
Inv diode	Green flashing
Output diode	Green
State diode	Red

When the inverter is started, the inverter outputs the power to the inverter output (normal operation). After switching to the inverter's power supply, the Bypass LED goes out and the inverter's LED goes green as follows:

LED	State
Rec diode	Green
Battery diode	Red
Bypass diode	Turn off
Inv diode	Green
Output diode	Green
State diode	Red

Close the battery breaker on the UPS (for both units in parallel operation), eg on the battery rack. The red battery light goes out. Then the batteries are charged by the UPS. UPS works in normal mode.

4.4.2 Starting the UPS from the battery

1. Check that the batteries are connected. Close the battery breaker on the UPS (repeat the operation on both units in case of parallel power supply operation).
2. Press and hold the red "cold start" button for 3 seconds (in the case of parallel operation of the power supplies, repeat operation on both units).

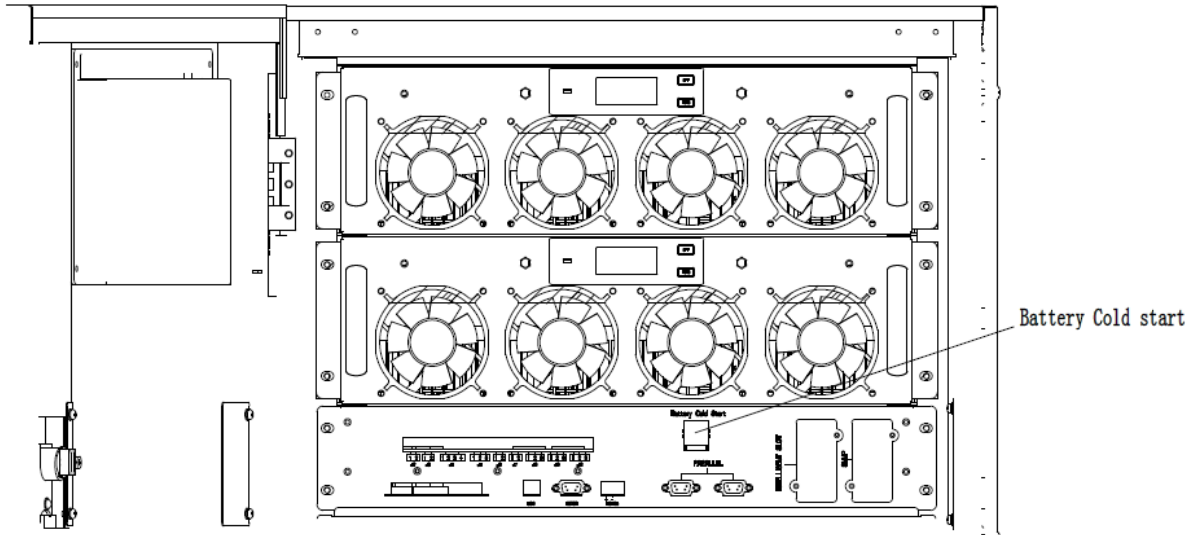

During commissioning, the LCD is turned on. The battery light flashes. When the charger is running for about 30 seconds, the battery light starts to glow green.

Warning. If the green battery light does not blink, it means that you need to press the red "cold start" button again.

3. The inverter starts up automatically, the inverter's LED blinks. The power supply is turned off after approximately 60 seconds.
4. Turn on output switch Q4 - only for HS 505 UPS or external output circuit breaker for HS 205 and HS 305.

 Attention	The "Battery Cold Start" switch is standard on the HS 305 and HS 505. The HS 205 is optional.
--	---

4.2 Procedures for switching the power supply between modes

4.2.1 Switching from normal to battery mode

The following procedure applies to both the operation of a single power supply and the parallel power supply.

Open the rectifier power switch located in the UPS power switch to disconnect the UPS. For HS 505, you can use the Q1 power switch disconnect behind the front UPS door. UPS will go into battery mode. If the power supply is to be switched back to normal operation, wait a few seconds and then close the power supply disconnect switch. After approximately 10 seconds, the rectifier is started and the mode is switched to normal mode.

4.2.2 Switching from Normal to Bypass mode

There are two ways to switch the power supply to Bypass mode.

Method 1: Enter the Operation menu and select the command "Transfer to Bypass" on the LCD (icon ).

Method 2: Press and hold the BYP key for two seconds on the UPS power panel until the UPS is in bypass mode. For this to work on the UPS rear door, switch SW1 must be in the ON position.

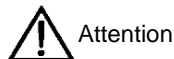
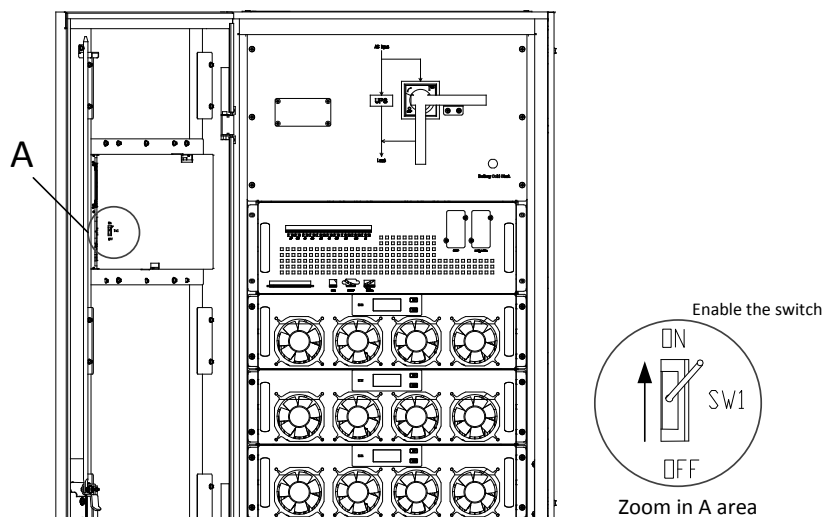

Attention

In Bypass mode, the loads are powered directly from the network and are not protected against the effects of power outages and interruptions.

4.2.3 Switching from Bypass mode to normal operation.

Method 1: Enter the Operation menu and select the command "Transfer to Inverter" on the LCD (icon ).

Method 2: Hold down the INV key on the power supply panel for more than 2 seconds.

4.2.4 Switching from Normal to Service bypass mode.

The following procedures allow you to switch the UPS from normal to maintenance bypass (Bypass mode).



Before performing the following procedure, make sure that the voltage and frequency parameters in the Bypass line are correct and that the inverter is synchronized to the Bypass voltage. Fulfillment of these conditions guarantees uninterrupted switching of the supply to bypass.

1. Follow the procedure for switching the power supply to the electronic bypass mode described in 4.2.2

Power supply is in Bypass mode, UPS inverter is off.

2. Open the battery switch and close the maintenance bypass switch (Maintenance Bypass). Receipts will be powered by bypass by electronic bypass and service bypass.
3. Open the rectifier feed circuit breaker (Q1 for HS 505), bypass circuit (Q2 for HS 505) and Q4 output disconnecter only for HS 505. For UPS up to 300kVA, the bypass and rectifier circuit breakers should be in the UPS power switchboard



If it is necessary to open the power module enclosures, eg during the review, wait at least 10 minutes until the DC capacitors are discharged inside the module.

4.2.5 Switching from Bypass mode to normal operation

The following procedure allows you to switch the power supply from bypass (Bypass service) to normal operation.

1. Close the bypass switch located in the UPS power distribution board for HS 205 and HS 305 or UPS bypass input Q2 for UPS HS 505.
2. Close the rectifier power switch located in the UPS power distribution board for the HS 205 and HS 305 or the UPS Main Input Q1 for the HS 505 UPS.
The Bypass LED will turn green after about 30 seconds, the power is supplied via an electronic bypass and service.
3. Close the battery switch located outside the UPS. The battery light goes out.
4. Open the Maintenance bypass switch.

The power is fed via an electronic bypass. In the meantime the rectifier will start up and after about 30 seconds the rectifier diode should glow green. Then the power supply inverter will automatically start - it may take about 1 minute.

In the case of parallel operation, you must perform successively on each UPS unit.

4.3 Complete power off procedure

To completely switch off the UPS and powered receivers, proceed to step 4.2.4 to Bypass service and then disconnect the UPS from the power switchboard.

4.4 Emergency shutdown with EPO

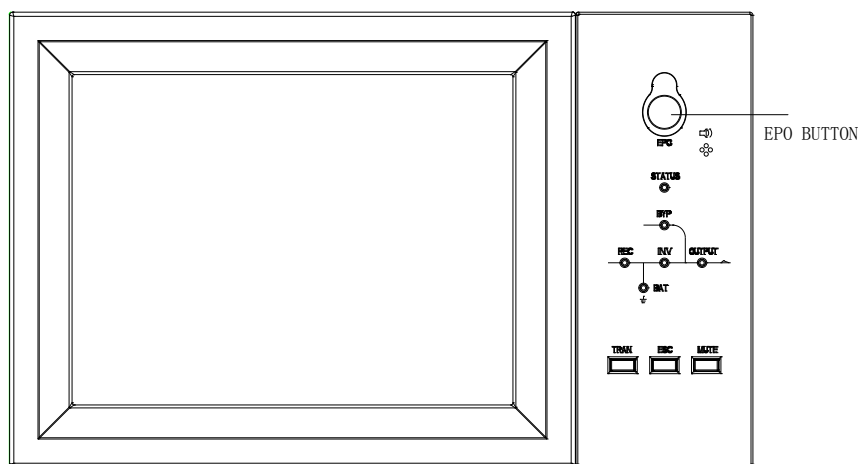

The UPS Emergency Power Button is located on the front panel of the UPS and is used for emergency shutdown in the event of a flood, fire, etc. The EPO circuit breaker immediately extinguishes the rectifier, inverter and disconnects the UPS output and stops charging or discharging the battery.

To start the UPS for normal operation after using EPO, restore the emergency stop to its normal position and supply the UPS voltage. The power supply will start normal operation automatically.



4.5 Battery test

Battery tests in the power supply can be carried out in two ways:

Method 1: It consists in manually turning on the battery test. To do this, go to the OPERATE menu shown in the figure below and then click the "Battery maintenance" icon . UPS will switch to battery mode. The discharge process will end automatically when the battery reaches 20% capacity or low battery voltage is reached. The discharge process can also be terminated by touching the "Stop Test" icon .

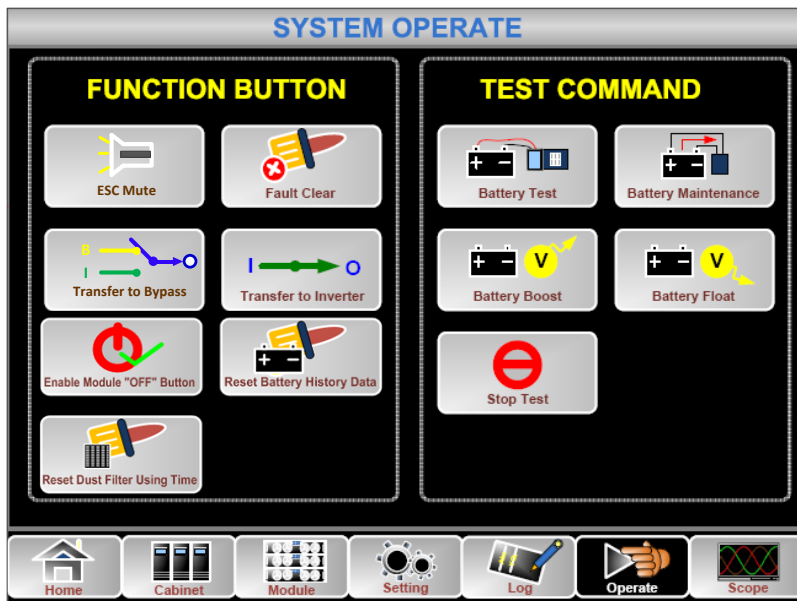

Method 2: It is based on automatic periodic battery tests, performed automatically by UPS after proper configuration. To enable automatic battery tests:

1. Turn on periodic battery test. Enter the "CONFIGURE" window shown in the figure below in the Settings menu and select and confirm "Battery Auto Discharge". (This option is only available through the service).
2. Specify the period of automatic testing. Open the "BATTERY" tab in the Settings menu. Set the desired battery test period in the "Auto Maintenance Discharge Period" field and confirm the change.

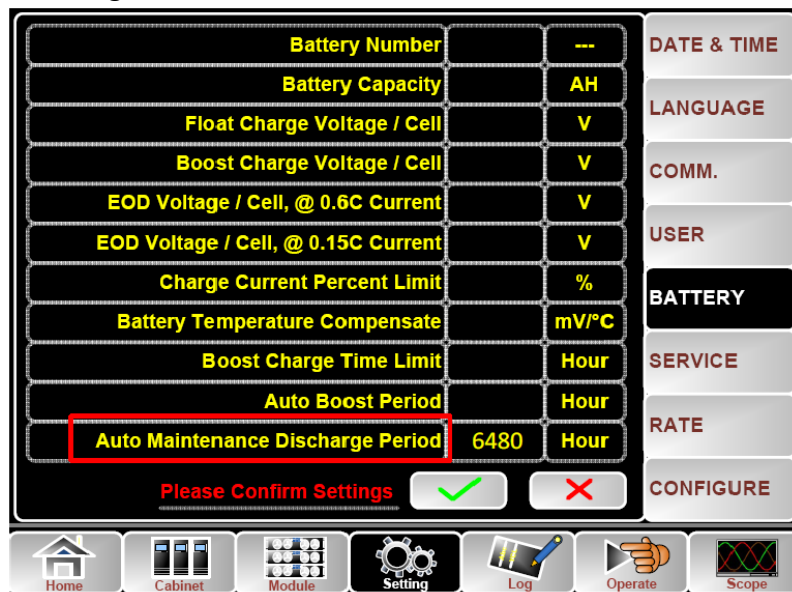

Warning! Battery tests will only be performed if the UPS is under load. The test load required is 20-100%.

5 LCD panel support

The following section describes the functions and capabilities of the control panel in the power supply, including key functions and available information from the LCD touch screen.

5.1 Introduction

The power supply panel with LCD display is located on the front panel of the UPS. The LCD display gives the user full access to work status monitoring, switching between operating modes as well as control of work parameters and event logging. The power supply control panel is divided into three sections, as shown in the figure below. There is a LED display of energy flow and status of each power supply module, LCD display, and keypad with EPO switch. The symbol details shown on the LCD panel are explained in the table below.

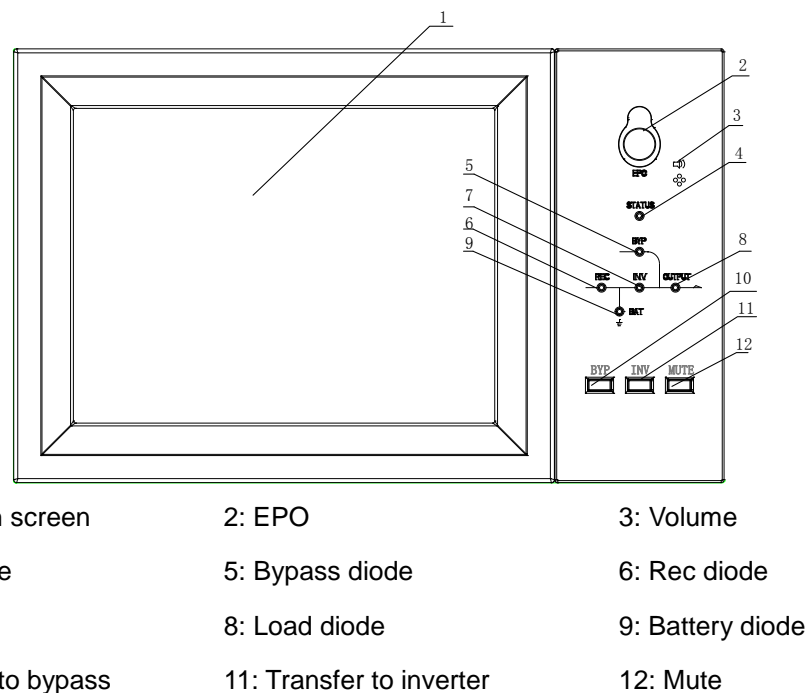

Figure 5-1 View of the power supply control panel.

5.1.1 LED indicators.

The LED energy flow diagram shows the current status of the power supply, the power flow in the UPS, and the state of the individual UPS components. Detailed description of each diode below.

Table 5-1 A description of the meaning of each state of the LED indicator

Indicator	State	Description
Rectifier diode	Green	Rectifier OK in all modules
	Green flashing	Rectifier of at least one module ok, power supply in normal
	Red	Rectifier failure
	Red flashing	Power at least one module out of the norm
	Blanked	Rectifier turn off
Battery diode	Green	Charging the battery
	Green flashing	Discharging the battery
	Red	Incorrect battery status (battery failure, no batteries attached or reverse polarity) or DC / DC converter (damage, overload or overheat), EOD (battery cut off voltage).
	Red flashing	Battery low voltage
	Blanked	Batteries and converter OK, batteries are not charged
Bypass diode	Green	Receivers supplied from bypass
	Red	Power Bypass beyond normal or static-switch failure.
	Red flashing	Bypass voltage is invalid
	Blanked	Bypass OK
Inverter diode	Green	Receivers supplied from inverter
	Green flashing	Switch on the inverter, turn on, synchronize at least one power module
	Red	Receivers are not powered from the inverter, at least one inverter module is faulty
	Red flashing	At least one inverter inverter is faulty
	Blanked	Inverter off in all modules
Load diode	Green	The UPS output is switched on and working properly
	Red	Prolonged overload of the power supply, short circuit at the output or no power at the output.
	Red flashing	Output overload
	Blanked	No voltage on output
State diode	Green	Normal work
	Red	Fault

5.1.2 Audible alarm

There are two types of acoustic signaling in the UPS. Both are described in the table below.

Alarm	Description
Two short alarms and one long one	Appears when events such as power outages occur.
Continuous alarm	It appears when a power supply fault occurs, such as a fuse or other component failure.

5.1.3 Function keys

There are 4 keys on the power board. The meaning of the keys is described below. To activate a particular function, long press the selected key.

Key	Function
EPO	Emergency power switch off.
BYP	Switching to Bypass mode
INV	Switching to inverter mode
MUTE	Mute or unmute the speaker

5.2 LCD touch screen display

After self-diagnosis, the UPS display should look like the figure below.

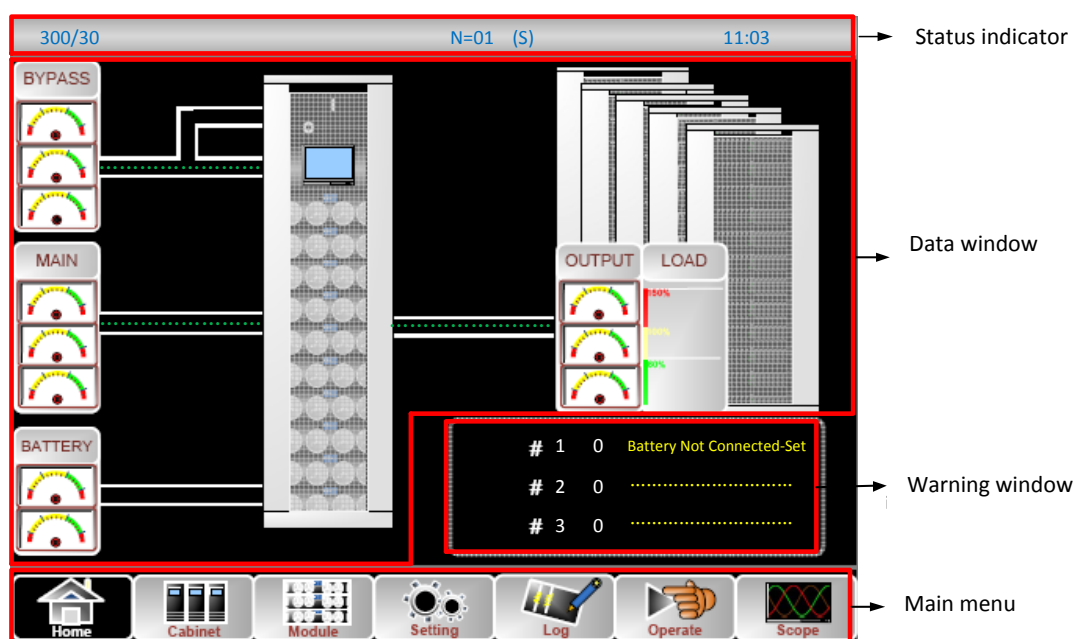

Figure 5-2 LCD screen

Status Indicator - describes the UPS model, power, operating mode, number of installed power modules, and system time.

Warning window - Contains current warnings.

Data window - a window containing a series of information about the entire UPS system. The user is able to read, among other things, the voltage of the bypass and rectifier voltage, battery voltage, output voltage. Values of these parameters are indicated in the form of an analog meter.

Power loads are displayed as a percentage scale. Green graph indicates load below 60%, yellow field defines a load in the range of 60-100%, Red field appears after exceeding 100% load.

Main Menu - The menu contains several tabs described as: Cabinet, Module, Setting, Log, Operate and Scope. You have the ability to navigate between windows to get information about UPS parameters, settings, event history, and more.

The menu structure looks like the figure below:

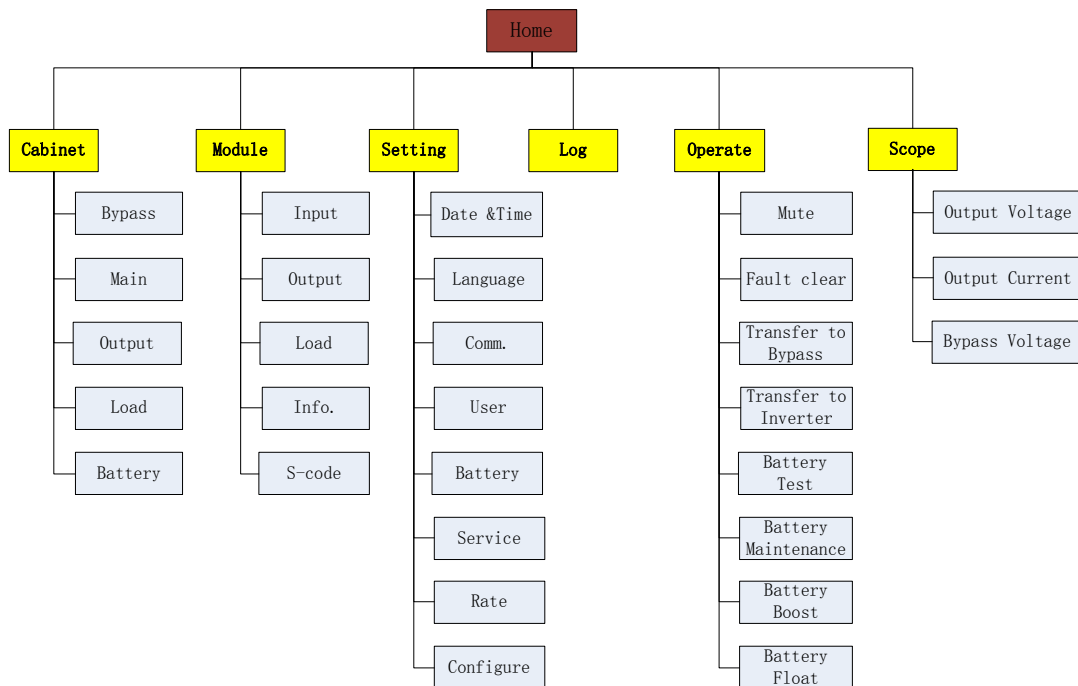



Figure 5-3 UPS menu structure

5.2.1 Main menu

The main menu of the power supply consists of tabs (windows) Cabinet, Module, Setting, Log, Operate and Scope. All of these windows are explained in detail in the descriptions below.

5.2.2 Cabinet

Touch icon  (In the bottom left of the panel), the system switches to Cabinet window display mode shown below.

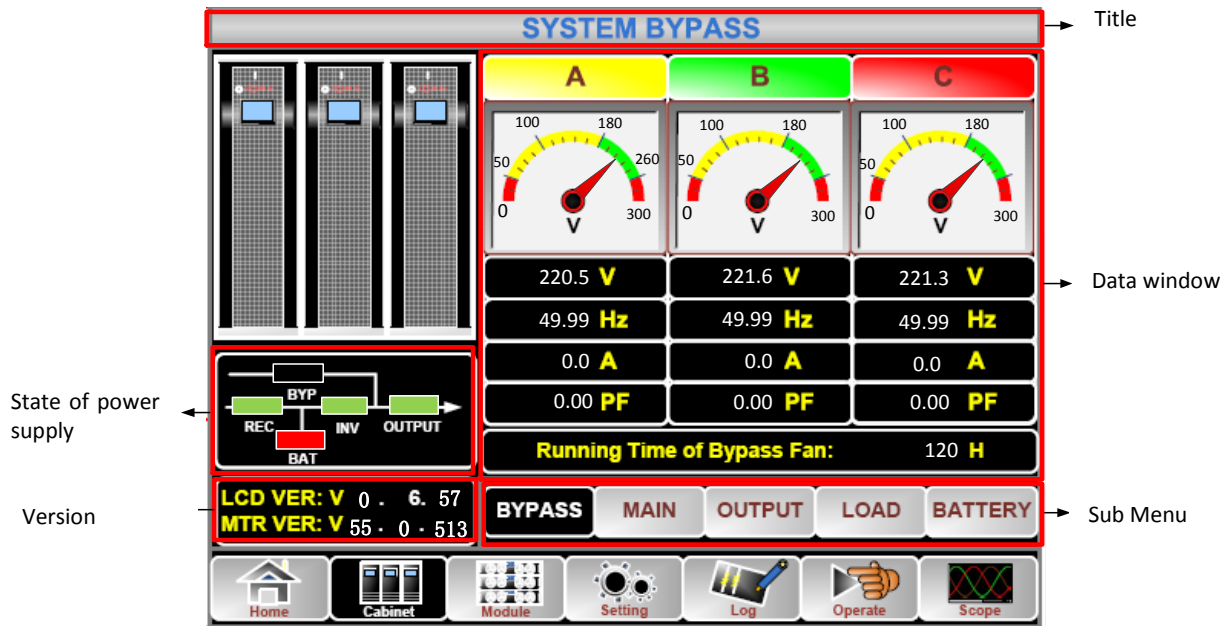

Title – Displays the name of the sub-menu that is currently displayed on the LCD screen.

State of power supply – different power supply components, such as rectifier, inverter, batteries, bypass, are marked as a flow chart. Components marked green indicate their correct operation, the white color of the component indicates that the component is missing, and the red color indicates that the component is missing or damaged.

Version – Specifies software version of power modules and LCD panel.

Sub Menu – Includes additional windows that display information about the performance of individual UPS components. Submenu consists of windows described as: Bypass, Main, Output, Load and Battery.

Data window – Displays all information about the selected submenu.

Example of appearance of individual windows The submenu is shown below:

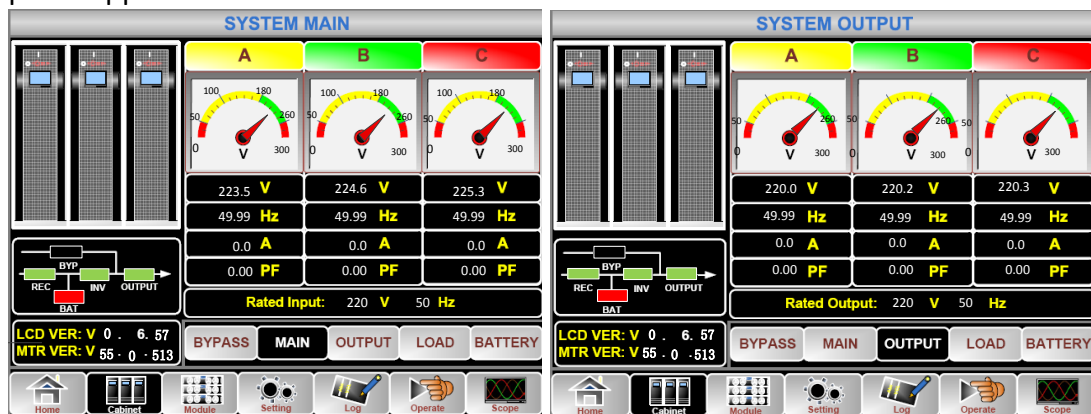

(a) MAIN window appearance

(b) OUTPUT window appearance

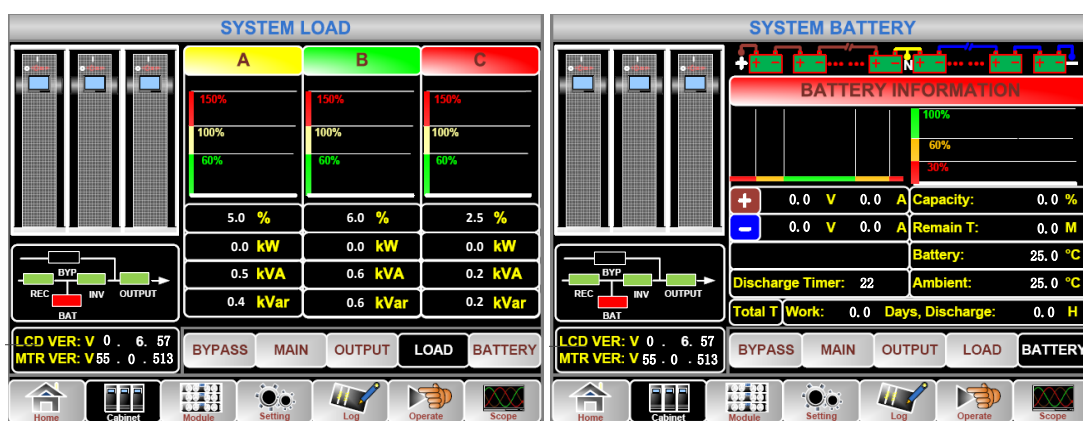

In the table below the list of parameters that can be read in each of the submenus:

Name of submenu	Unit	Description
Main	V	Phase voltage
	A	Phase current
	Hz	Input frequency
	PF	Power factor
Bypass	V	Phase voltage
	A	Phase current
	Hz	Bypass frequency
	I	Phase Current
Output	V	Phase voltage
	A	Phase current
	Hz	Output frequency
	PF	Power factor
Load	kVA	Sout: Apparent power
	kW	Pout: active power
	kVar	Qout: reactive power
	%	Load
Battery	V	Battery voltage +/-
	A	Battery current +/-
	Capacity (%)	Remaining capacity
	Remain T (Min.)	Remaining battery time
	Battery(°C)	Battery temperature

Name of submenu	Unit	Description
	Ambient(°C)	Environmental temperature
	Total Work T	Total working time
	Total Discharge T	Total working time from battery

5.2.3 Module

Touch icon  (In the bottom left of the panel), the system switches to the Module window display mode shown below.

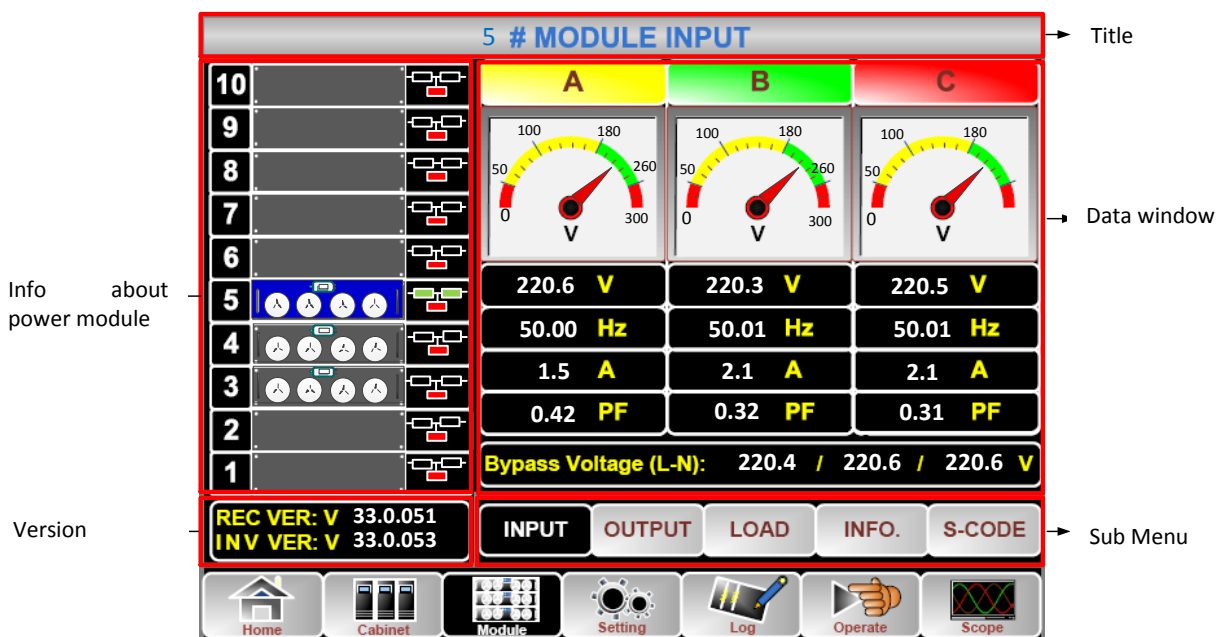

Title – Displays the name of the sub-menu that is currently displayed on the LCD screen.

Data window – Displays all information about the selected submenu.

Information about power module – The user has the option of selecting the module whose parameters are to be displayed in the data window. The fill colors of the individual power module components determine the state of their operation:

- Green – Normal work
- Black – module is fail
- Red – module is broken

Version – Specifies the software version of the inverter and the power module rectifier.

Sub Menu – Includes additional windows that display information on the performance of individual UPS modules. The submenu consists of the input, output, load, info and S-code windows.

Example of appearance of individual windows The submenu is shown below:

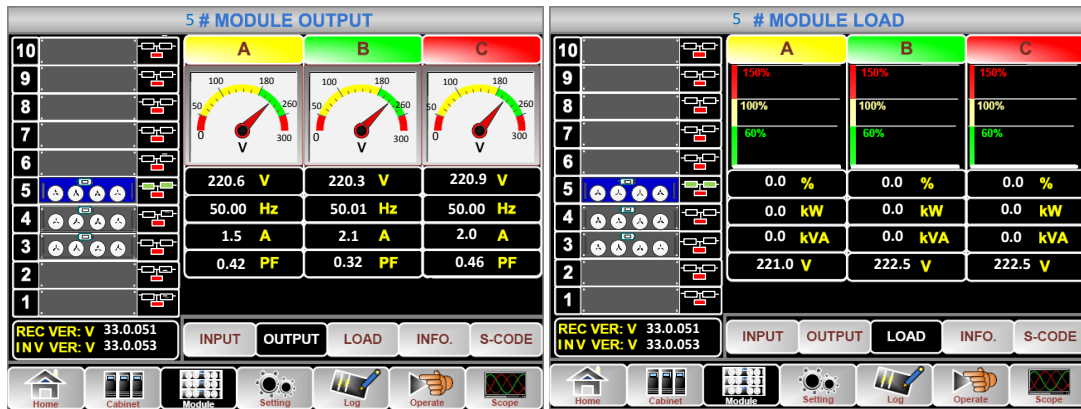

(a) OUTPUT

(b) LOAD



(c) INFORMATION

(d) S-Code

Name of Sub menu	Unit	Description
Main	V	Phase voltage of the module
	A	Phase current of the module
	Hz	Input frequency of the module
	PF	Power factor of the module
Bypass	V	Phase voltage of the module
	A	Phase current of the module
	Hz	Bypass frequency of the module
	PF	Power factor of the module
Load	V	Output voltage of the module
	%	Load of the selected module

Name of Sub menu	Unit	Description
	KW	Pout: Active power
	KVA	Sout: Apparent power
Information	BATT+(V)	Battery voltage +
	BATT-(V)	Battery voltage -
	BUS(V)	Voltage BUS +-
	Charger(V)	Battery charging voltage +-
	Fan Time	Total operating time of the module
	Inlet Temperature(°C)	Inlet air temperature module
	Outlet Temperature(°C)	Air outlet temperature module
S-code	Fault Code	For Service

5.2.4 Setting

Touch icon  (at the bottom of the panel), the system will switch to the setting mode shown below:

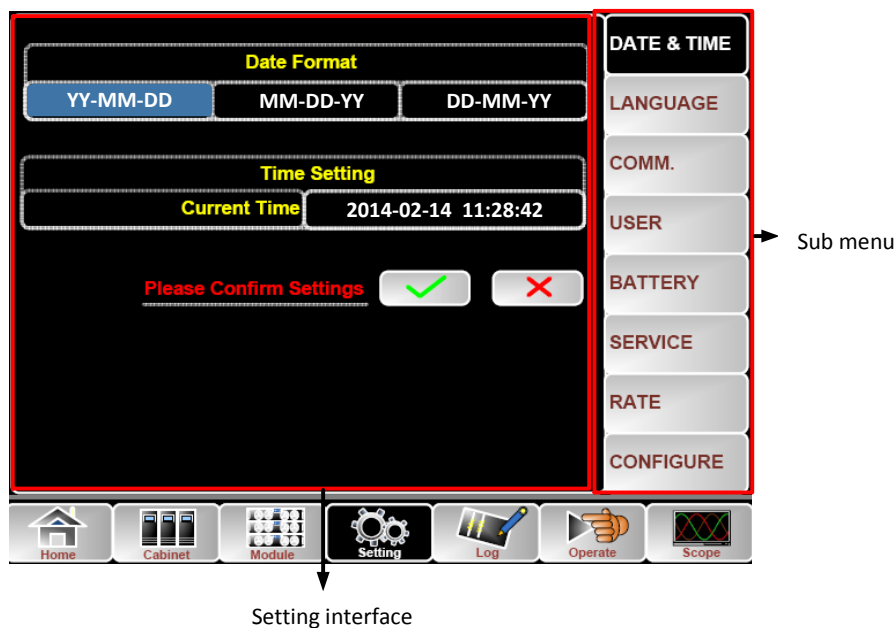

All possible UPS settings are contained in the windows that are available in the submenu on the right hand side of the LCD. The settings submenu contains a list of windows described as: Date & Time, Language, Comm., User, Battery, Service, Rate, and Configure.

The table below explains the meaning and possibility of changes in the individual settings windows.

<i>Sub menu</i>	<i>Parameter</i>	<i>Description</i>
<i>Date&Time</i>	<i>Date format setting</i>	<i>There are three possible selection formats (A) year / month / day, (b) month / day / year, (C) day / month / year</i>
	<i>Time setting</i>	<i>Setting date and time</i>
<i>Language</i>	<i>Current language</i>	<i>Language in current use</i>
	<i>Language selection</i>	<i>English or chinese</i>
<i>COMM.</i>	<i>Device Address</i>	<i>Set device address</i>
	<i>RS232 Protocol Selection</i>	<i>SNT, ModBus, YD/T or Dwin (for service)</i>
	<i>Baudrate</i>	<i>Set the read speed for the communication protocol</i>
	<i>Modbus Mode</i>	<i>ASCII or RTU</i>
	<i>Modbus parity</i>	<i>Parity setting for Modbus</i>
<i>USER</i>	<i>Output voltage Adjustment</i>	<i>Setting the voltage value</i>
	<i>Bypass Voltage Up Limited</i>	<i>To choose:+10%, +15%, +20%, +25%</i>
	<i>Bypass Voltage Down Limited</i>	<i>To choose:-10%, -15%, -20%, -30%, -40%</i>
	<i>Bypass Frequency Limited</i>	<i>To choose : +/-1Hz, +/-3Hz, +/-5Hz</i>
	<i>Dust Filter Maintenance Period</i>	<i>Set the date of the replacement of the pollen filter</i>
<i>BATTERY</i>	<i>Battery Number</i>	<i>Setting the amount of battery (12V)</i>
	<i>Battery Capacity</i>	<i>Setting the battery capacity (Ah)</i>
	<i>Float Charge Voltage/Cell</i>	<i>Set the charging voltage in float mode for the battery cell (2V)</i>
	<i>Boost Charge Voltage/Cell</i>	<i>Charging voltage setting in boost mode for battery cell (2V)</i>
	<i>EOD(End of charge) Voltage/Cell,@0.6C Current</i>	<i>Setting the battery disconnect voltage when discharging 0.6xC</i>
	<i>EOD (End of charge) Voltage/Cell,@0.15C Current</i>	<i>Set the voltage of disconnecting the battery when discharged with 0.15xC</i>
	<i>Charge Current Percent Limit</i>	<i>Set the percentage of battery charger performance</i>
	<i>Battery Temperature Compensate</i>	<i>Set the temperature correction factor of the charging voltage</i>
	<i>Boost Charge Time Limit</i>	<i>Setting the charging time in boost mode</i>
	<i>Auto Boost Period</i>	<i>Setting the auto boost load duration</i>
<i>Auto Maintenance Discharge Period</i>	<i>Set the period of automatic battery tests</i>	

Sub menu	Parameter	Description
SERVICE	System Mode	Single ,parallel, Single ECO, parallel ECO,LBS, parallel LBS
RATE	Configure the rated Parameter	For service
CONFIGURE	Configure the system	For service

You have access to the Date and Time settings, the communication protocol, and the language without a password. Other settings are available after entering a Level 1 or Level 2 pass, available only by the manufacturer's authorized service provider.

5.2.5 Log

Touch icon  (At the bottom of the panel), the system switches to the Log window display mode shown below. The Event log window displays all events and alarms that occurred during the operation. Each event specifies the exact date and time of occurrence and resignation.

NO.	M# EVENTS	TIME
1	0 # Load On UPS-Set	2014 - 2 - 14 16 :26 : 1
2	4 # Module Inserted-Set	2014 - 2 - 14 16 :24 : 27
3	0 # Byp Freq Over Track-Set	2014 - 2 - 14 16 :22 : 31
4	0 # Load On Bypass-Set	2014 - 2 - 14 16 :21 : 33
5	0 # Bypass Volt Abnormal-Set	2014 - 2 - 14 16 :21 : 33
6	0 # Load On Bypass-Set	2014 - 2 - 14 16 :19 : 41
7	0 # No Load-Set	2014 - 2 - 14 16 :18 : 45
8	4 # Load On Bypass-Set	2014 - 2 - 14 16 :18 : 45
9	0 # Byp Freq Over Track-Set	2014 - 2 - 14 16 :18 : 45
10	4 # Module-Exit-Set	2014 - 2 - 14 16 :26 : 1

Total Log Items 29

Home Cabinet Module Setting Log Operate Scope



Each occurrence is recorded in history (League contains exact time and date of occurrence, sequence number, event description and highlighted in red box.

Event Sequence Number (NO.) - specifies the number of events in reverse order to the time that occurred. The earliest events are number one.

Event Description (M # EVENTS) - Displays a description of the event, warning, or damage. The number given before the description indicates the location of the event: 0 # - system casing, n # - where n = 1,2, ... 10 refers to the specific power module. Power modules are counted from below.

Event Time (TIME) - specifies the exact date and time of the event.

Total Log Items - Determines the total number of recorded events. The maximum number of events that can be saved is 895. When this number is exceeded, the oldest entries are deleted.

Arrow keys   - Allows you to scroll through the history of events.

Each event can be displayed in four colors that have a specific meaning:

- Green - the event has appeared and continues.
- Gray - the event has appeared and subsided.
- Yellow - a warning has appeared and continues.
- Red – damage.

5.2.6 Operate

Touch icon  (At the bottom of the panel), the system switches to the Log window display mode shown below.

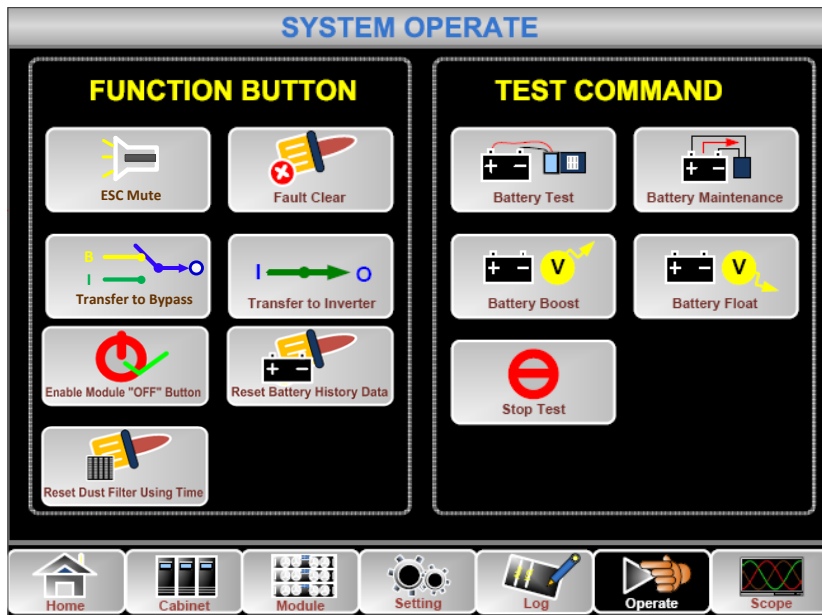



The Operate menu contains function icons and commands, each key description is described below:

Function keys:

Mute or turn on sound – Depending on the status, the icon may take a look  or .

Clear alarms – Possible by clicking the icon .

Enable or disable bypass mode – Possible with icons  (transfer to bypass mode) and  (turn off the bypass mode).

Turn on inverter – touching icon  allows to transfer from bypass mode to inverter.

Ability to disable power module - To access the power module off from the OFF key on the module, click the icon .

Clear history of battery events – touching icon  allows to clear all history according time of charging, amount of discharge etc.

Clear the history of the use of the pollen filter – touching icon  allows you to delete the entire story associated with the use of the filter, exchange dates, etc.

Command keys:

Battery test – Touching icon  Allows the system to switch to battery mode for battery testing. Ensure bypass is available and battery capacity is greater than 25% before testing.

Battery support – Touching icon  Allows the system to switch to battery mode to check the battery. Ensure bypass is available and battery capacity is greater than 25% before testing.

Boost charging – Touching icon  enables accelerated loading in boost mode.





Float charging – Touching icon  allows Float to load in normal mode.

Stop test – Touching icon  interrupts the battery test.

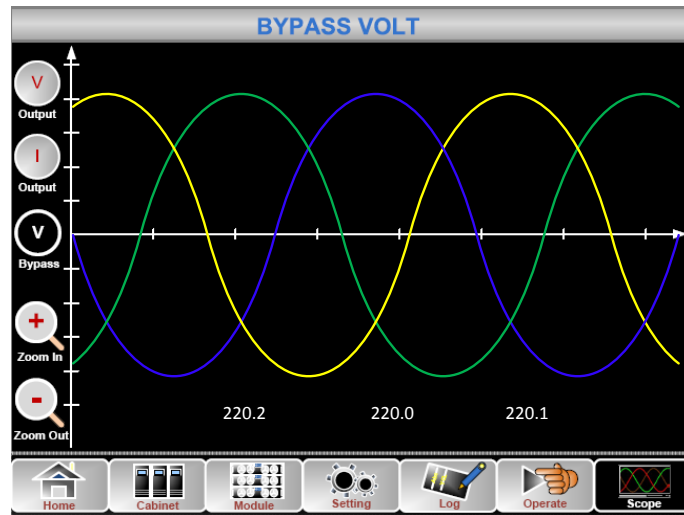
5.2.7 Scope

Touching icon  (In the lower right part of the panel), the system will switch to the oscilloscope window display mode shown below.



The oscilloscope function allows the user to view the voltage waveforms  and current  on output of system, and bypass voltage . Keys   allows you to zoom in or out.