

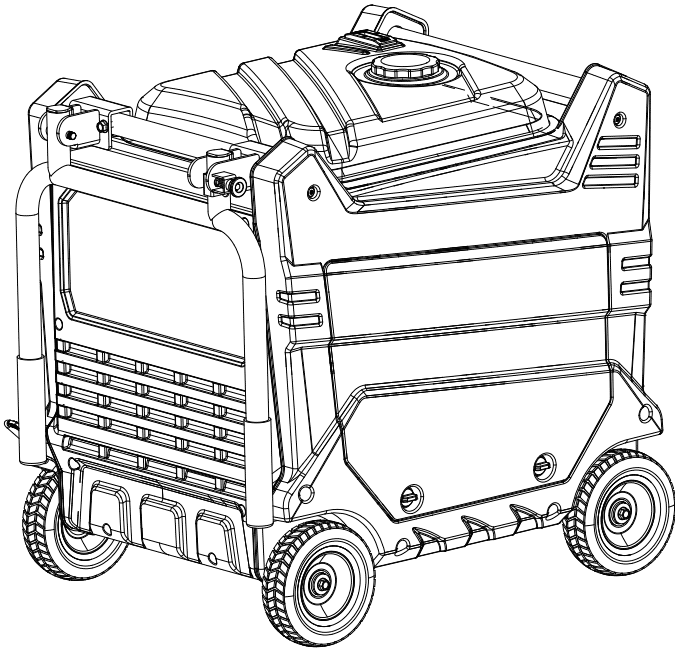

**OWNER'S MANUAL & OPERATION INSTRUCTION**



# **INVERTER GENERATOR**

---

**SAVE THIS MANUAL:** This manual contains important information regarding safety, operation, maintenance and storage of this product. Before use, read carefully and understand all cautions, warnings, instructions and product labels. Failure to do so could result in serious personal injury and/or property damage.

Congratulations on your selection of this generator. We are certain you will be pleased with your purchase of one of the finest generators on the market.

We want to help you get the best results from your new generator and to operate it safely. This manual contains the information on how to do that, please read it carefully.

When your generator needs scheduled maintenance, keep in mind that your servicing dealer is specially trained in servicing generators and is supported by the parts and service divisions. Your servicing dealer is dedicated to your satisfaction and will be pleased to answer your questions and concerns.

Model:	XL8000ii
Starting Watts:	7500W
Running Watts:	7000W
Ac Voltage:	230V
Frequency:	50Hz
Phase:	Single
Fuel Capacity:	26L
Engine:	SC460(459cc)
Engine Oil:	1.0L

# INTRODUCTION

---

## A FEW WORDS ABOUT SAFETY

Your safety and the safety of others are very important. And using this generator safely is an important responsibility.

To help you make informed decisions about safety, we have provided operating procedures and other information on labels and in this manual. This information alerts you to potential hazards that could hurt you or others.

Of course, it is not practical or possible to warn you about all the hazards associated with operating or maintaining a generator. You must use your own good judgment.

Record the model and serial numbers as well as date and place of purchase for future reference. Have this information available when ordering parts and when making technical or warranty inquiries.

<b>Model Number</b>
<b>Serial Number</b>
<b>Date of Purchase</b>

# CONTENTS

---

IMPORTANT SAFETY INSTRUCTIONS .....	5
SYMBOLS .....	8
ELECTRICAL .....	9
FEATURES .....	11
ASSEMBLY .....	14
OPERATION .....	15
MAINTENANCE .....	22
TROUBLESHOOTING .....	28
PARTS ASSEMBLY .....	29
PARTS LIST .....	30



# IMPORTANT SAFETY INSTRUCTIONS



## DANGER:

**Carbon Monoxide.** Using a generator indoors CAN KILL YOU IN MINUTES.

Generator exhaust contains high levels of carbon monoxide (CO), a poisonous gas you cannot see or smell. If you can smell the generator exhaust, you are breathing CO. But even if you cannot smell the exhaust, you could be breathing CO.

- Never use a generator inside homes, garages, crawlspaces, or other partly enclosed areas. Deadly levels of carbon monoxide can build up in these areas. Using a fan or opening windows and doors does NOT supply enough fresh air.
- ONLY use a generator outdoors and far away from open windows, doors, and vents. These openings can pull in generator exhaust.

Even when you use a generator correctly, CO may leak into the home. ALWAYS use a battery-powered or battery-backup CO alarm in the home.

If you start to feel sick, dizzy, or weak after the generator has been running, move to fresh air RIGHT AWAY. See a doctor. You could have carbon monoxide poisoning.



## WARNING:

Read and understand all instructions. Failure to follow all instructions listed below could result in electrocution, fire, and/or carbon monoxide poisoning, which can cause death or serious injury



## WARNING:

National Electric Code requires generator to be grounded to an approved earth ground. Before using the ground terminal, consult a qualified electrician, electrical inspector, or local agency having jurisdiction for local codes or ordinances that apply to the intended use of the generator.

## SAVE THESE INSTRUCTIONS

This manual contains important instructions for this product that should be followed during installation and maintenance of the generator.

- Do not connect to a building's electrical system unless the generator and transfer switch have been properly installed and the electrical output has been verified by a qualified electrician. The connection must isolate the generator power from utility power and must comply with all applicable laws and electrical codes.
- Do not allow children or untrained individuals to use this unit.
- Do not start or operate the engine in a confined space, building, near open windows, or in other unventilated space where dangerous carbon monoxide fumes can collect. Carbon monoxide, a colorless, odorless, and extremely dangerous gas, can cause unconsciousness or death.
- Keep all bystanders, children, and pets at least 10 feet away.

# IMPORTANT SAFETY INSTRUCTIONS

---

- Wear sturdy and dry shoes or boots. Do not operate while barefoot.
- Do not operate generator when you are tired or under the influence of drugs, alcohol, or medication.
- Keep all parts of your body away from any moving parts and all hot surfaces of the unit.
- Do not touch bare wire or receptacles.
- Do not use generator with electrical cords which are worn, frayed, bare, or otherwise damaged.
- Before storing, allow the engine to cool and drain fuel from the unit.
- Do not operate or store the generator in rain, snow, or wet weather.
- Store the generator in a well-ventilated area with the fuel tank empty. Fuel should not be stored near the generator.
- Empty fuel tank, turn the engine/choke lever to the off position and restrain the unit from moving before transporting in a vehicle.
- Allow engine to cool for five minutes before refueling.
- To reduce the risk of fire and burn injury, handle fuel with care. It is highly flammable.
- Do not smoke while handling fuel.
- Store fuel in a container approved for gasoline.
- Position the unit on level ground, stop engine, and allow to cool before refueling.
- Wipe spilled fuel from the unit.
- Loosen fuel cap slowly to release pressure and to keep fuel from escaping around the cap.
- Tighten the fuel cap securely after refueling.
- Never attempt to burn off spilled fuel under any circumstances.
- Generators vibrate in normal use. During and after the use of the generator, inspect the generator as well as extension cords and power supply cords connected to it for damage resulting from vibration. Have damaged items repaired or replaced as necessary. Do not use plugs or cords that show signs of damage such as broken or cracked insulation or damaged blades.
- For power outages, permanently installed stationary generators are better suited for providing back-up power to the home. Even a properly connected portable generator can become overloaded. This may result in overheating or stressing the generator components, possibly leading to generator failure.
- Use only authorized replacement parts and accessories and follow instructions in the Maintenance section of this manual. Use of unauthorized parts or failure to follow maintenance instructions may create a risk of shock or injury.
- Maintain the unit per maintenance instructions in this Operator's Manual.
- Inspect the unit before each use for loose fasteners, fuel leaks, etc. Replace damaged parts.

# IMPORTANT SAFETY INSTRUCTIONS



## **WARNING:**

**When this generator is used to supply a building wiring system:** generator must be installed by a qualified electrician and connected to a transfer switch as a separately derived system. The generator shall be connected through a transfer switch that switches all conductors other than the equipment grounding conductor. The frame of the generator shall be connected to an approved grounding electrode. Failure to isolate the generator from power utility can result in death or injury to electric utility workers.



- Do not use this generator to provide power for emergency medical equipment or life support devices.
  - Exhaust contains poisonous carbon monoxide, a colorless, odorless gas. Breathing exhaust can cause loss of consciousness and can lead to death. If running in a confined or partially-enclosed area, the air may contain a dangerous amount of carbon monoxide. To keep exhaust fumes from building up, always provide adequate ventilation.
  - Always use a battery-powered carbon monoxide detector when running the generator. If you begin to feel sick, dizzy, or weak while using the generator, shut it off and get to fresh air immediately. See a doctor. You may have carbon monoxide poisoning.
- Place the generator on a flat, stable surface with a slope of no more than 4°.
  - Operate outdoors in a well-ventilated, well-lit area isolated from working areas to avoid noise interference.
  - Operate outdoors in a well-ventilated, well-lit area isolated from working areas to avoid noise interference.
  - Operating the generator in wet conditions could result in electrocution. Keep the unit dry.
  - Keep the generator a minimum of 3 feet away from all types of combustible material.
  - Do not operate generator near hazardous material.
  - Do not operate generator at a gas or natural gas filling station.
  - Do not touch the muffler or cylinder during or immediately after use; they are HOT and will cause burn injury.
  - This generator has a neutral floating condition. This means the neutral conductor is not electrically connected to the frame of the machine.
  - Do not allow the generator's gas tank to overflow when filling. Fill to 1 in. below the top neck of the gasoline tank to allow for fuel expansion. Do not cover the fuel tank cap when the engine is running. Covering the fuel tank cap during use may cause engine failure and/or damage to the tool.

# IMPORTANT SAFETY INSTRUCTIONS

- Do not smoke when filling the generator with gasoline.
- Shut down the engine and allow to cool completely before adding gasoline or lubricant to the generator.
- Do not remove the oil dipstick or the fuel tank cap when the engine is running.
- Pay close attention to all safety labels located on the generator.
- Keep children a minimum of 10 feet away from the generator at all times.
- The unit operates best in temperatures between 23°F and 104°F with a relative humidity of 90% or less.
- Operating voltage and frequency requirement of all electronic equipment should be checked prior to plugging them into this generator. Damage may result if the equipment is not designed to operate within a +/- 10% voltage variation, and +/- 3 hz frequency variation from the generator name plate ratings.
- For outdoor use only.
- Save these instructions. Refer to them frequently and use them to instruct others who may use this product. If you loan someone this product, loan them these instructions also.

## SYMBOLS

The following signal words and meanings are intended to explain the levels of risk associated with this product.

SYMBOL	SIGNAL	MEANING
	<b>DANGER:</b>	Indicates an imminently hazardous situation, which, if not avoided, will result in death or serious injury.
	<b>WARNING:</b>	Indicates a potentially hazardous situation, which, if not avoided, could result in death or serious injury.
	<b>CAUTION:</b>	Indicates a potentially hazardous situation, which, if not avoided, may result in minor or moderate injury.
	<b>NOTICE:</b>	(Without Safety Alert Symbol) Indicates important information not related to an injury hazard, such as a situation that may result in property damage.

# ELECTRICAL

## GENERATOR CAPACITY

Make sure the generator can supply enough running (rated) and starting (max.) watts for the items you will power at the same time. Follow these simple steps.

1. Select the items you will power at the same time.
2. Total the running (rated) watts of these items. This is the amount of power the generator must produce to keep the items running.
3. Estimate how many starting (max.) watts you will need. Starting wattage is the short burst of power needed to start electric motor-driven tools or appliances such as a circular saw or refrigerator. Because not all motors start at the same time, total starting (max.) watts can be estimated by adding only the item(s) with the highest additional starting (max.) to the total rated watts.

### Example:

Tool or Appliance	Running Watts*	Additional Starting Watts*
Refrigerator	700	1350
Portable Fan	40	120
Laptop	250	250
46 in. Flat Panel Television	190	190
Light (75 Watts)	75	75
	1255 Total Running Watts	1350 Highest Starting Watts

$$\begin{array}{r} \text{Total Running Watts} \quad 1255 \\ \text{Highest Starting Watts} \quad + 1350 \\ \hline \text{Total Starting Watts Needed} \quad 2605 \end{array}$$

## GENERATOR CAPACITY

To prolong the life of the generator and attached devices, it is important to take care when adding electrical loads to the generator. There should be nothing connected to the generator outlets before starting its engine. The correct and safe way to manage generator power is to sequentially add loads as follows:

1. With nothing connected to the generator, start the engine as described later in this manual.

# ELECTRICAL

---

2. Plug in and turn on the first load, preferably the largest load you have.
  3. Permit the generator output to stabilize (engine runs smoothly and attached device operates properly).
  4. Plug in and turn on the next load.
  5. Again, permit the generator to stabilize.
  6. Repeat steps 4 and 5 for each additional load.
- Never add more loads than the generator capacity. Take special care to consider surge loads in generator capacity as previously described.

**NOTICE:**

Do not overload the generator's capacity. Exceeding the generator's wattage/amperage capacity may damage the generator and/or electrical devices connected to it.

# FEATURES

---

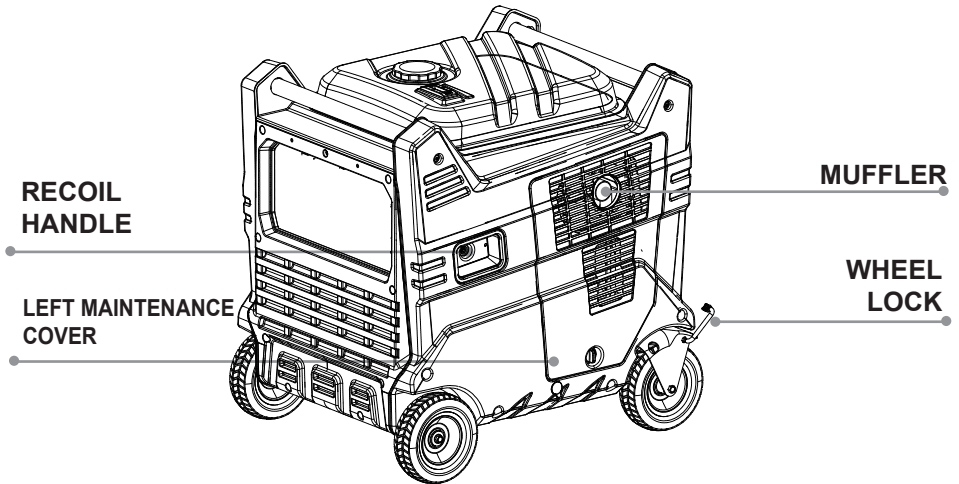
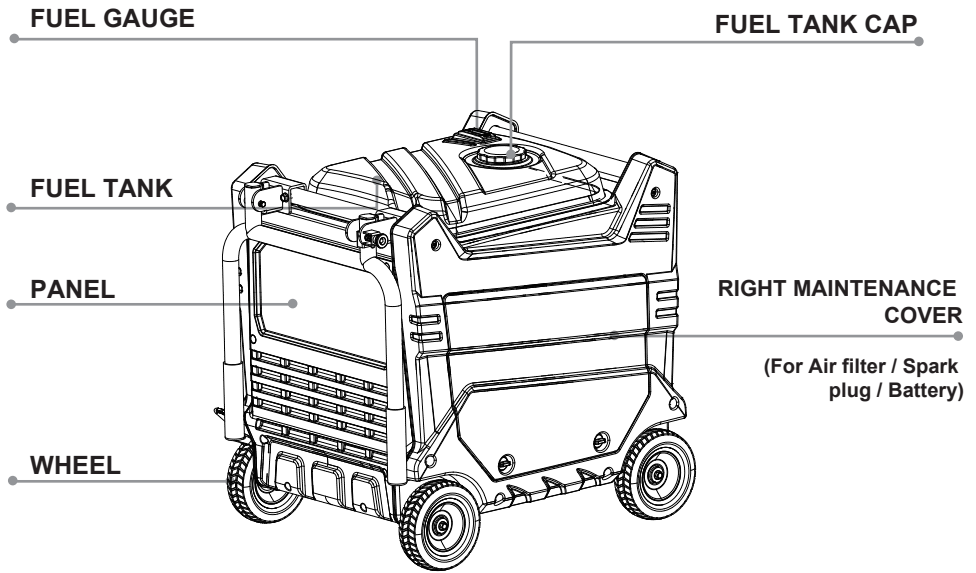

# FEATURES

---

## KNOW YOUR GENERATOR

The safe use of this product requires an understanding of the information on the product and in this operator's manual as well as a knowledge of the project you are attempting. Before use of this product, familiarize yourself with all operating features and safety rules.

## AC RECEPTACLES

The receptacles can be used for operating appropriate appliances, electrical lighting, tools, and motor loads.

## AIR FILTERS

The air filters help to limit the amount of dirt and dust drawn into the unit during operation.

## LOW IDLE MODE

The low idle mode is used to control the speed of the engine and conserve fuel. When the switch is in the ON (I) position and no appliances are connected to the unit, the engine will idle. If an appliance is added, the engine speed will increase to power the item. If the appliance is removed, the engine will return to idle.

### NOTICE:

If high electrical loads are connected simultaneously, turn the low idle mode to the OFF position to reduce voltage changes.

## HANDLES

The generator is equipped with two handles for easy transport. Both handles should be used to move the generator.

## FUEL TANK

To provide increased operating time, start with a full tank before operation. Always refuel with the engine OFF and cool.

## FUEL GAUGE

The fuel gauge is a mechanical device that measures the fuel level in the tank. The red indicator in the window will reference the level in relation to full or empty.

## GROUND TERMINAL

The ground terminal is used to assist in properly grounding the generator to help protect against electrical shock. Consult with a local electrician for grounding requirements in your area.

## LED DISPLAY

LEDs provide feedback to indicate whether the generator is in use, overloaded, or in need of lubricant.

## OIL CAP/DIPSTICK

Remove the oil fill cap to check and add lubricant to the generator when necessary.

## PARALLEL KIT (Optional)

The non-polarized parallel kit terminals are used with a parallel kit (sold separately) that will allow generators to be linked together to increase output.

**NOTE:** Read and understand the parallel kit's instructions prior to use. Kit is for usage with this unit only.



# FEATURES

---

## **STARTER GRIP**

Used when the battery voltage is too low to turn the starter motor. Pulling the starter grip to manual start the generator's engine.

## **VOLTAGE SELECTOR SWITCH (Optional)**

Select the voltage before starting the engine.

Always disconnect or turn OFF all appliances or tools connected to the generator before changing the voltage selector switch position.

The voltage selector switch changes generator output to produce "120V ONLY" or "120 V/240 V". If a 240 V appliance is connected to the 4-prong receptacle, the switch must be in the "120 V/240 V" position. If only the 120 V 3-prong receptacles are being used, select the "120 V ONLY" position.

Switch Position

120 V/240 V: The 120 V and 120/240 V receptacles can be used simultaneously.

120 V ONLY: ONLY the 120 V receptacles can be used. Do not use the 120V/240 V receptacle in this position.

The most power will be available at the 30 A 120 V locking plug receptacle.

## **DC RECEPTACLE (Optional)**

Your generator has a 12 volt DC receptacle for charging lead acid batteries.

## **MULTI-SWITCH**

The multi-switch is used to control the fuel and choke.

## **MAINTENANCE COVER**

Open and close the maintenance cover for maintenance of the generator.

Open the right maintenance cover for:

- Air filter inspection/cleaning
- Spark plug inspection/replacement
- Battery inspection/replacement

Open the left maintenance cover for:

- Engine oil inspection/replacement

# ASSEMBLY

## UNPACKING

This product has been shipped completely assembled.

- Carefully remove the product and any accessories from the box. Make sure that all items listed in the packing list are included.



### WARNING:

Do not use this product if any parts on the Packing List are already assembled to your product when you unpack it. Parts on this list are not assembled to the product by the manufacturer and require customer installation. Use of a product that may have been improperly assembled could result in serious personal injury.

- Inspect the product carefully to make sure no breakage or damage occurred during shipping.
- Do not discard the packing material until you have carefully inspected and satisfactorily operated the product.
- If any parts are damaged or missing, please call for assistance.



### WARNING:

If any parts are damaged or missing do not operate this product until the parts are replaced. Use of this product with damaged or missing parts could result in serious personal injury.



### WARNING:

Do not attempt to operate the generator until assembly is complete. Failure to comply could result in possible serious personal injury.



### WARNING:

Do not attempt to modify this product or create accessories not recommended for use with this product. Any such alteration or modification is misuse and could result in a hazardous condition leading to possible serious personal injury.

## PACKING LIST

Generator  
Battery Charging Cable (Optional)  
Engine Lubricant (Optional)  
Screwdriver  
Funnel  
Operator's Manual

# OPERATION

## **DANGER:**

**Carbon Monoxide.** Using a generator indoors **CAN KILL YOU IN MINUTES.**

Generator exhaust contains high levels of carbon monoxide (CO), a poisonous gas you cannot see or smell. If you can smell the generator exhaust, you are breathing CO. But even if you cannot smell the exhaust, you could be breathing CO.

- Never use a generator inside homes, garages, crawlspaces, or other partly enclosed areas. Deadly levels of carbon monoxide can build up in these areas. Using a fan or opening windows and doors does NOT supply enough fresh air.
- ONLY use a generator outdoors and far away from open windows, doors, and vents. These openings can pull in generator exhaust.

Even when you use a generator correctly, CO may leak into the home. ALWAYS use a battery-powered or battery-backup CO alarm in the home.

If you start to feel sick, dizzy, or weak after the generator has been running, move to fresh air RIGHT AWAY. See a doctor. You could have carbon monoxide poisoning.

## **WARNING:**

Do not allow familiarity with this product to make you careless. Remember that a careless fraction of a second is sufficient to inflict serious injury.

## **DANGER:**

Failure to properly ground generator can result in electrocution, especially if the generator is equipped with a wheel kit. Call an electrician for local grounding requirements.

### GROUNDING THE GENERATOR

To reduce the risk of shock or electrocution, generator must be properly grounded. The nut and ground terminal on the frame must always be used to connect the generator to a suitable ground source. Connect the terminal of the ground wire between the lock washer and the nut, and tighten the nut fully. Connect the other end of the wire securely to a suitable ground source.

All electrical tools and appliances operated from this generator must be properly grounded by use of a third wire or be "Double Insulated."

Check and adhere to all applicable federal, state, and local regulations relating to grounding specifications. Consult a qualified electrician or service personnel if the grounding instructions are not completely understood or if in doubt as to whether the generator is properly grounded.

## **WARNING:**

Do not use any attachments or accessories not recommended by the manufacturer of this product. The use of attachments or accessories not recommended can result in serious personal injury.

# OPERATION

## CONNECTING BATTERY

### WARNING:

To reduce the risk of electrocution or explosion, do not short circuit the battery terminals or charge in a sealed container. Keep sparks and flame away.

### WARNING:

Keep metal objects away from the battery terminals. Metal objects can make a connection from one terminal to another. Shorting the battery terminals together can cause sparks, burns, or a fire.

### NOTICE:

The battery may require charging before the generator can be started using either the engine switch or the recoil starter. Once the generator is started, the battery will charge as the unit runs.

The battery cables must be connected before the generator can be operated.

### To connect battery cables:

- Loosen the screws at the side of the right maintenance cover. Remove cover and set aside.
- Connect the red wires to the positive (+) terminal first, then connect the black wire to the negative (-) terminal. Make sure all connections are tight.
- Cover the terminals with the rubber covers.

**NOTE:** Be careful not to short across the terminals when installing. Shorting the terminals together can cause sparks, damage to the battery or generator, or even burns or explosions.

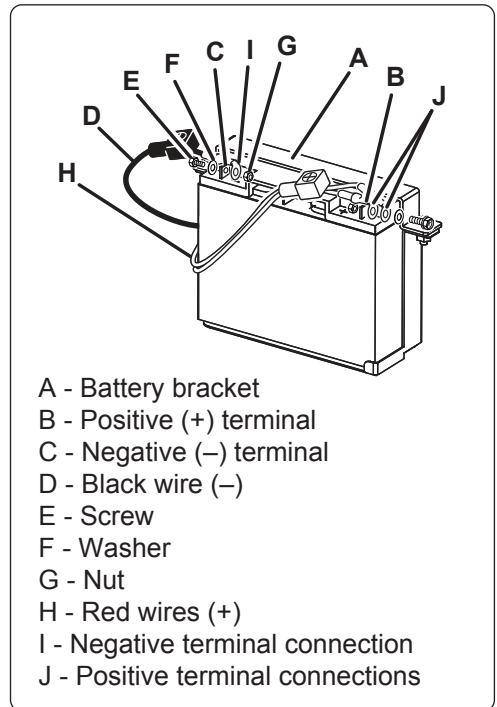
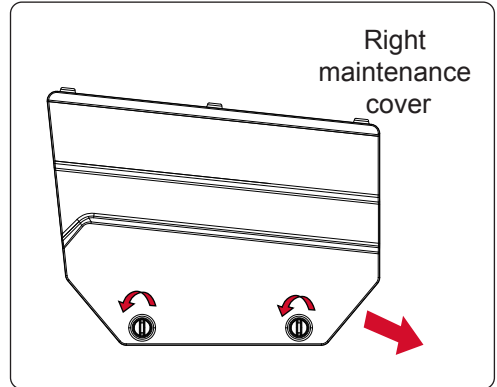

# OPERATION

## CHECKING/ADDING ENGINE OIL

The generator is equipped with two handles for easy transport. Both handles should be used to move the generator.

### NOTICE:

Attempting to start the engine before it has been properly filled with engine oil will result in equipment failure.

Engine oil has a major influence on engine performance and service life. For general, all-temperature use, SAE 10W-30 is recommended. Always use a 4-stroke engine oil that meets or exceeds the requirements.

**NOTE:** Non-detergent or 2-stroke engine oil will damage the engine and should not be used.

- Loosen the screws at the side of the left maintenance cover. Remove cover and set aside.
- Unscrew the oil cap/dipstick and remove.
- Wipe dipstick clean and re-seat in hole; do not re-thread.
- Remove dipstick again and check engine oil level. Engine oil level should fall between the minimum and maximum marks on the dipstick.
- If level is low, add engine oil.
- Replace and secure the cap/dipstick.

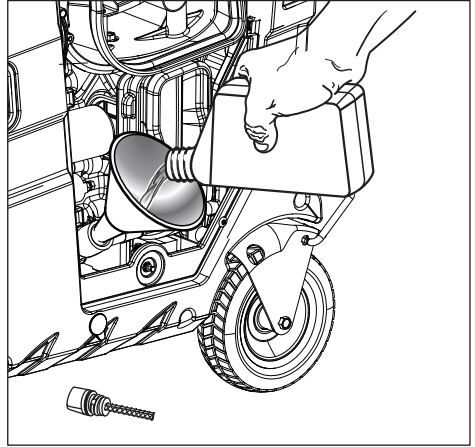
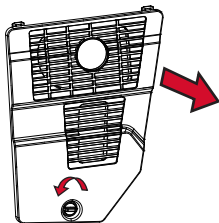

## USING FUEL STABILIZER

Fuel gets old, oxidizes, and breaks down over time. Adding a fuel stabilizer (not included) extends the usable life of fuel and helps prevent deposits from forming that can clog the fuel system. Follow fuel stabilizer manufacturer's directions for correct ratio of stabilizer to fuel.

- Mix fuel stabilizer and gasoline prior to filling the tank by using a gas can or other approved fuel container and shaking gently to combine.

**NOTE:** To control the amount of fuel stabilizer being added to the engine, always mix fuel stabilizer with gasoline before fueling the tank rather than adding fuel stabilizer directly into the generator's fuel tank.

- Replace and secure fuel tank cap.
- Start and run the engine for at least 5 minutes to allow stabilizer to treat the entire fuel system.

# OPERATION

## OXYGENATED FUELS

### NOTICE:

Do not use E15 or E85 fuel (or fuel containing greater than 10% ethanol) in this product. It is a violation of federal law and will damage the unit and void your warranty.

Fuel system damage or performance problems resulting from the use of an oxygenated fuel containing more than the percentage of oxygenates stated below **are not covered under warranty.**

Ethanol. Gasoline containing up to 10% ethanol by volume (commonly referred to as E10) is acceptable. **E15 and E85 are not.**

## CHECKING/ADDING FUEL

### ⚠ WARNING:

Gasoline and its vapors are highly flammable and explosive. To prevent serious personal injury and property damage, handle gasoline with care. Keep away from ignition sources, handle outdoors only, do not smoke while adding fuel, and wipe up spills immediately.

When adding gas to the generator, make sure the unit is sitting on a flat, level surface. If the engine is hot, let the generator cool before adding gas. ALWAYS fill the fuel tank outdoors with the machine turned off.

- Remove the fuel cap.
- Fill the fuel tank to 1 in. below the top of the fuel neck.

- Replace and secure the fuel cap.

**NOTE:** Always use unleaded gasoline with a pump octane rating of 86 or higher. Never use old, stale, or contaminated gasoline, and do not use an oil/gas mixture. Do not allow dirt or water into the fuel tank. **Do not use E85 fuel.**

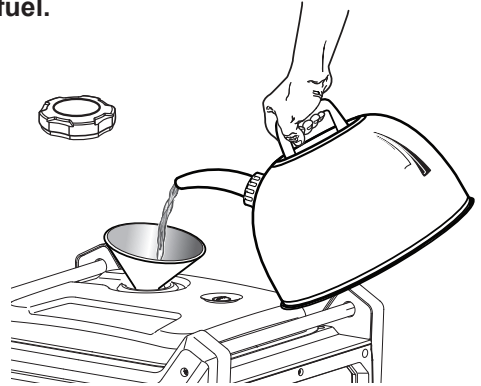

## STARTING THE ENGINE

### NOTICE:

On a level surface with the engine off, check the lubricant level before each use of the generator.

**NOTE:** If location of generator is not level, the unit may not start or may shut down during operation.

### NOTICE:

Do not place the generator directly on the ground when using the unit in grassy areas or in areas with dense vegetation. Doing so could result in grass discoloration and/or localized soil damage.

# OPERATION

- Unplug all loads from the generator.
- Place the low idle mode in the OFF position. (If you wish to use the low idle mode, turn the low idle mode to the ON position after the engine has warmed up for 2 or 3 minutes.)
- Turn the fuel switch to the ON position.
- Turn the main switch to the ON position.

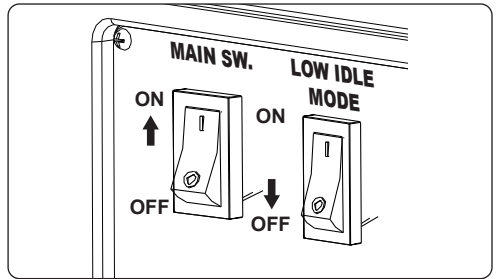

- **FOR ELECTRIC START:** Turn and hold the Engine START/STOP Switch.

The Engine START/STOP Switch functions for 5 seconds. As soon as the engine starts, the starter will stop automatically.

If the engine fails to start, wait at least 10 seconds before operating the starter again.

**FOR MANUAL START:** Use the recoil starter when the battery voltage is too low to turn the starter motor.

- Pull the starter grip lightly until you feel resistance; then pull briskly in the direction of the arrow as shown.

**NOTE:** Do not allow the grip to snap back after starting; return it gently to its original place.

- Plug to the generator.

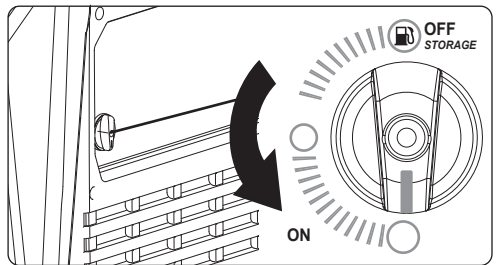

## FOR ELECTRIC START:

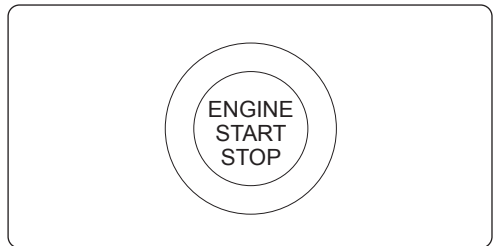

## FOR MANUAL START:

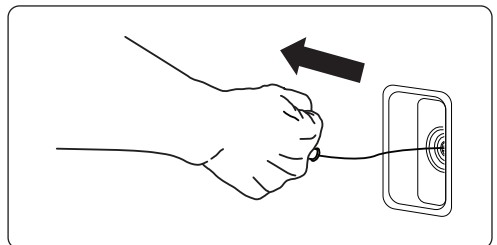

# OPERATION

## STOPPING THE ENGINE

- Remove any load from the generator.
- Turn the Main Switch to the OFF position.
- Turn the Fuel Switch to the OFF position.

### To stop the engine in an emergency situation:

- Turn the Main Switch to the OFF position.

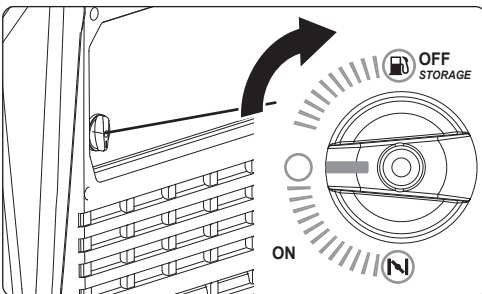
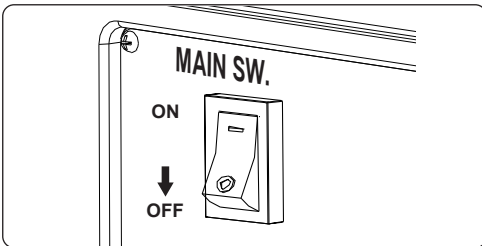
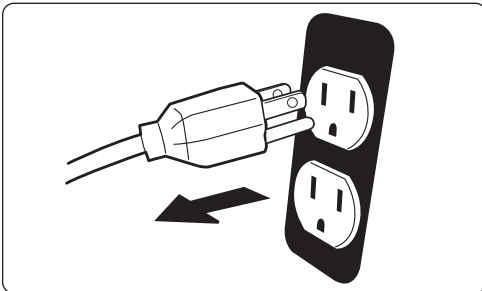

## **WARNING:**

While operating and storing, keep at least 3 feet of clearance on all sides of this product, including overhead. Allow a minimum of 30 minutes of “cool down” time before storage. Heat created by muffler and exhaust gases may be hot enough to cause serious burns and /or ignite combustible objects.

## AC APPLICATIONS

Before connecting an appliance or power cord to the generator:

- Make sure that it is in good working order. Faulty appliances or power cords can create a potential for electrical shock.
- If an appliance begins to operate abnormally, becomes sluggish, or stops suddenly, turn it off immediately. Disconnect the appliance, and determine whether the problem is the appliance or the rated load capacity of the generator has been exceeded.

Most appliance motors require more than their rated wattage for startup.

Make sure the electrical rating of the tool or appliance does not exceed the maximum power rating of the generator.

In either case, the total power requirements of all appliances connected must be considered. Appliance and power tool manufacturers usually list rating information near the model number or serial number.



# OPERATION

## PARALLEL OPERATION (Optional)

Before connecting an appliance to either generator, make sure that the appliance is in good working order and that its electrical rating does not exceed that of the receptacle.

Most motorized appliances require more than their electrical rating for startup. When an electric motor is started, the OVERLOAD indicator (red) may come ON. This is normal if the OVERLOAD indicator (red) goes OFF within 5 seconds. If the OVERLOAD indicator (red) stays ON, consult your generator dealer.

During parallel operation, the low idle mode should be in the same position on both generators.

Connect the parallel operation cable between two generators following the instructions supplied with the parallel kit.

## STANDBY POWER

### Connections to a Building's Electrical System

Connections for standby power to a building's electrical system must be made by a qualified electrician. The connection must isolate the generator power from utility power, and must comply with all applicable laws and electrical codes.

In some areas, generators are required by law to be registered with local utility companies. Check local regulations for proper registration and use procedures.



### WARNING:

Improper connections to a building's electrical system can allow current from the generator to backfeed into the utility lines.

Such backfeed may electrocute utility company workers or others who contact the lines during a power outage, and the generator may explode, burn, or cause fires when utility power is restored.

Consult the utility company or a qualified electrician prior to making any power connections.

## HIGH ALTITUDE OPERATION

Specific modifications are needed for high-altitude operation. Please contact your authorized service center for important information regarding these modifications. Operating this engine without the proper altitude modification may increase the engine's emissions and decrease fuel economy and performance.

# MAINTENANCE

## **WARNING:**

When servicing, use only identical replacement parts. Use of any other parts could create a hazard or cause product damage.

## GENERAL MAINTENANCE

Keep the generator in a clean and dry environment where it is not exposed to dust, dirt, moisture, or corrosive vapors. Do not allow the cooling air slots in the generator to become clogged with foreign material such as leaves, etc.

Do not use a garden hose to clean the generator. Water entering the fuel system or other internal parts of the unit can cause problems that will decrease the life of the generator.

## CHECKING/CLEANING AIR FILTER

For proper performance and long life, keep air filter clean.

- Loosen the screws at the side of the right maintenance cover. Remove cover and set aside.
- Unsnap the air filter cover clip, pulling the cover down and off the unit, remove air filter cover and set aside.
- Remove the air filter.
- Wash the air filters with warm, soapy water. Rinse and squeeze to dry.
- Reinstall the air filters.

**NOTE:** Make sure the filters are seated properly inside the generator. Installing the filters incorrectly will allow dirt to enter the engine, causing rapid engine wear.

- Reinstall the air filter cover.
- Reinstall the right maintenance cover. Tighten screws to secure.

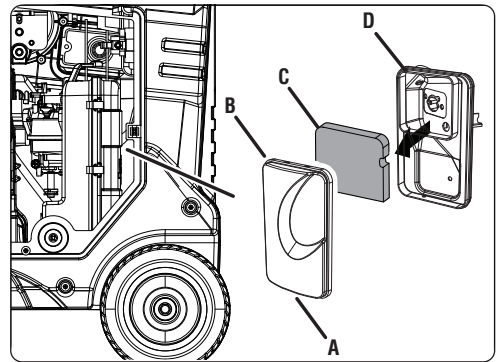
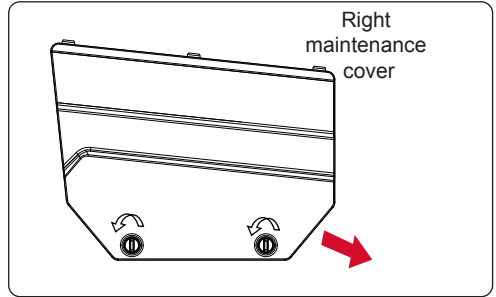

## CHANGING ENGINE OIL

For best performance, engine oil should be changed after every 100 hours or 6 months of operation.

**NOTE:** Drain the engine oil while the engine is still warm but not hot. Warm engine oil will drain quickly and more completely.

- Loosen the screws at the side of the left maintenance cover. Remove cover and set aside.

# MAINTENANCE

- Reach under the generator and remove the black rubber seal located below the oil drain plug.
- Place a suitable container underneath the generator to catch the used oil.
- Remove the oil fill cap/dipstick.
- Remove the other black rubber seal located in the front the oil drain plug.
- Use a wrench through the hole to remove the oil drain plug and allow the oil to drain completely.
- Reinstall the oil drain plug. Tighten the plug securely.
- Reinstall the two black rubber seal (the front one and the bottom one).
- With the generator in a level position and refill with engine oil following the instructions in the Checking/Adding engine oil section previously in this manual. For amount of engine oil needed to refill, see Product Specifications earlier in this manual or the accompanying engine manual, if applicable.
- Reinstall the oil cap/dipstick securely.
- Reinstall the left maintenance cover. Tighten screws to secure.

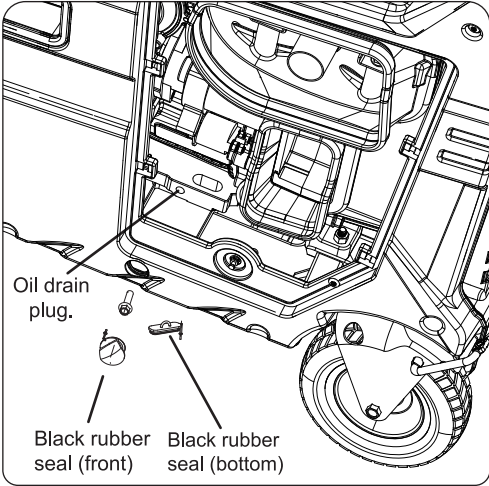
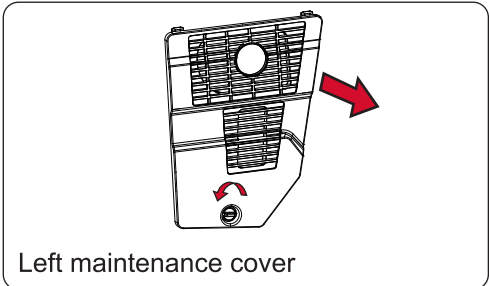

**NOTE:** Used engine oil should be disposed of at an approved disposal site. See local retailer for more information.

**WARNING:**  
Do not change engine oil while it is hot. Accidental contact with hot engine oil could result in serious burns.

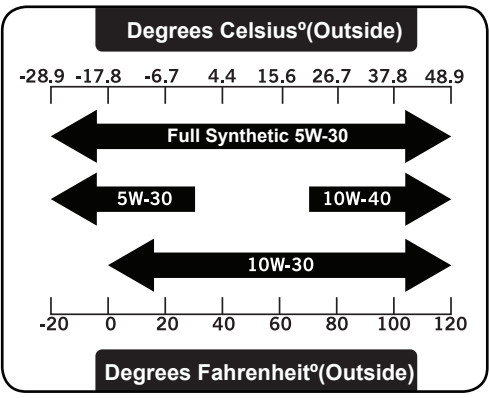

# MAINTENANCE

## SPARK PLUG REPLACEMENT

The spark plug must be properly gapped and free of deposits in order to ensure proper engine operation. If the engine is hot, allow it to cool before servicing the spark plug.

- Loosen the screws at the side of the right maintenance cover. Remove cover and set aside.
- Remove the spark plug cap.
- Clean any dirt from around base of spark plug.
- Remove spark plug using spark plug wrench.
- Inspect the spark plug. Replace it if the electrode is worn or fouled, or if the insulator is cracked or chipped.
- Measure the spark plug electrode gap with a wire-type feeler gauge. Correct the gap, if necessary, by carefully bending the side electrode. The gap should be:  
0.028-0.031 in (0.7-0.8mm)

- Seat spark plug in position; thread in by hand to prevent cross-threading.

If reinstalling a used spark plug, tighten 1/8-1/4 turn after the spark plug seats.

If installing a new spark plug, tighten 1/2 turn after the spark plug seats.

**NOTE:** An improperly tightened spark plug will become very hot and could damage the engine.

### NOTICE:

Be careful not to cross-thread the spark plug. Cross-threading will seriously damage the product.

- Attach the spark plug cap.
- Close the right maintenance cover.

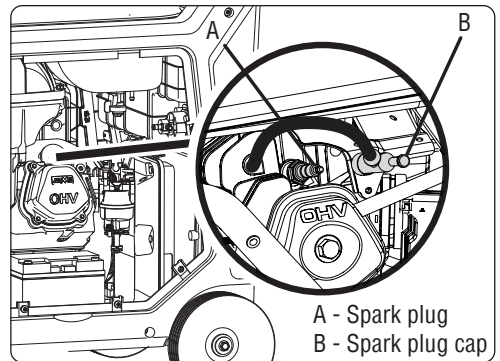
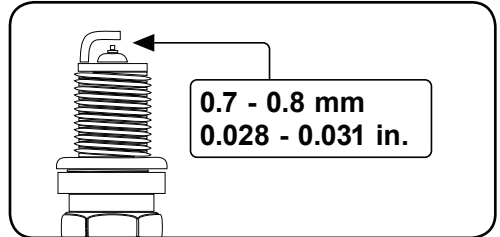

## SPARK ARRESTER SERVICE

The spark arrester must be serviced every 100 hours to keep it functioning as designed.

If the engine has been running, the muffler will be very hot. Allow the muffler to cool before servicing spark arrester.

- Remove the two screws, and remove the tail pipe and spark arrester.
- Use a brush to remove carbon deposits from the spark arrester screen. Be careful to avoid damaging the screen.

The spark arrester must be free of breaks and tears. Replace the spark arrester if it is damaged.

# MAINTENANCE

---

- Install the spark arrester in the reverse order of removal.

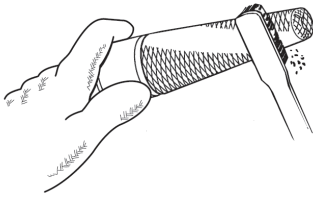

## DRAINING FUEL TANK / CARBURETOR

To help prevent gum deposits in the fuel system, drain the fuel from the tank and carburetor before storing.

### Draining the fuel tank:

Remove the fuel tank cap, remove the fuel strainer, and empty the fuel tank into an approved gasoline container. We recommend using a commercially available gasoline hand pump to empty the tank. Do not use an electric pump. Siphon the gasoline by inserting the tip of the hand pump into the side of the pump guard. Reinstall the fuel strainer and the fuel tank cap..

### Draining the carburetor:

- Loosen the screws at the side of the right maintenance cover. Remove cover and set aside.
- Turn the Multi-switch to the RUN position.
- Position a suitable container under the carburetor drain screw to catch fuel; loosen the screw.

- Allow fuel to drain completely into container.
- Retighten drain screw securely.
- Turn the Multi-switch to the OFF position.

## TRANSPORTING

- Turn the Multi-switch to the OFF position.
- Make sure engine and exhaust of unit is cool.
- Keep the generator level to reduce the possibility of fuel leakage.
- When using ropes or tie-down straps to secure the generator for transportation, be sure to only use the frame bars as attachment points. Do not fasten ropes or straps to any portions of the generator body or the folding transport handle.

# MAINTENANCE

## STORAGE

When preparing the generator for storage, allow the unit to cool for 30 minutes then follow the guidelines below.

STORAGE TIME	PRIOR TO STORING
Less than 2 months	■ Drain gasoline from tank and dispose of in a suitable container according to state and local ordinances.
2 months to 1 year	■ Drain gasoline from tank and dispose of in a suitable container according to state and local ordinances.
1 year or more	■ Remove spark plug. ■ Drain gasoline from tank and dispose of in a suitable container according to state and local ordinances. ■ Put a tablespoon of engine oil into the spark plug cylinder. Turn the engine slowly with the pull rope to distribute the engine oil. ■ Reinstall spark plug. ■ Change engine oil. ■ After removal from storage, fill with fresh gasoline.
<b>NOTE:</b> If storing gasoline in suitable container for later use, make sure gasoline has been treated with fuel stabilizer according to stabilizer manufacturer's instructions.	

# MAINTENANCE

## MAINTENANCE SCHEDULE

**NOTE:** If a separate engine manual is provided for this generator, please follow the maintenance schedule provided in the engine manual instead of the maintenance information listed below.

	Before each use	After 1st month or 20 hours	Every 3 months or 50 hours	Every 6 months or 100 hours	Every year or after 300 hours
Check Engine oil	●				
Change Engine oil		●		●	
Check Air Filter	●				
Clean Air Filter			●		
Change Air Filter					●
Check/Adjust Spark Plug				●	
Replace Spark Plug					●
Check/Adjust Idle Speed					●
Clean Fuel Tank & Filter				●	
Check Fuel Hose	●				
Fuel Filter	<b>Inspect</b>				<b>Replace</b>
Check/Adjust Valve Clearance					●
Clean Spark Arrester				●	

**NOTE:** Maintenance should be performed more frequently when generator is used in dusty areas.

When generator has exceeded the maximum figures specified in the table, maintenance should still be cycled according to the intervals of time or hours stated herein.

# TROUBLESHOOTING

## ENGINE WILL NOT START

Possible Cause	Solution
Battery not charged.	Charge battery.
Engine switch is in the OFF position.	Turn engine switch to the ON position.
No fuel.	Fill fuel tank.
Stale gasoline or water in gasoline.	Drain entire system and refill with fresh fuel.
Engine oil level is low.	Engine is equipped with Low Oil Shutoff. If engine oil level is low, it must be filled before unit will start. Check engine oil level and fill, if necessary.
Multi-switch is in OFF or Run position.	Turn multi-switch to the START position.
Spark plug faulty, fouled, or improperly gapped.	Replace spark plug.
Engine stored without treating or draining gasoline, or refueled with bad gasoline.	Drain fuel. Refuel with fresh gasoline.
Dirty fuel filter.	Replace fuel filter or contact a qualified service center.

## ENGINE LACKS POWER.

Possible Cause	Solution
Dirty air filter.	Check air filter element. Clean or replace as needed.
Engine stored without treating or draining gasoline, or refueled with bad gasoline.	Drain fuel. Refuel with fresh gasoline. If problem continues, contact a qualified service center.

## AC RECEPTACLE DOES NOT WORK.

Possible Cause	Solution
OUTPUT indicator is OFF, and OVERLOAD indicator is ON.	Check AC load. Stop and restart the engine. Check the cooling air inlet. Stop and restart the engine.
AC Circuit protector(s) tripped.	Check AC load and reset AC circuit protector(s)
GFCI system activated.	Reset the GFCI.
Item plugged in is defective.	Try a different item.

If problem persists after trying the above solutions, contact your nearest authorized service center for assistance.



# PARTS ASSEMBLY

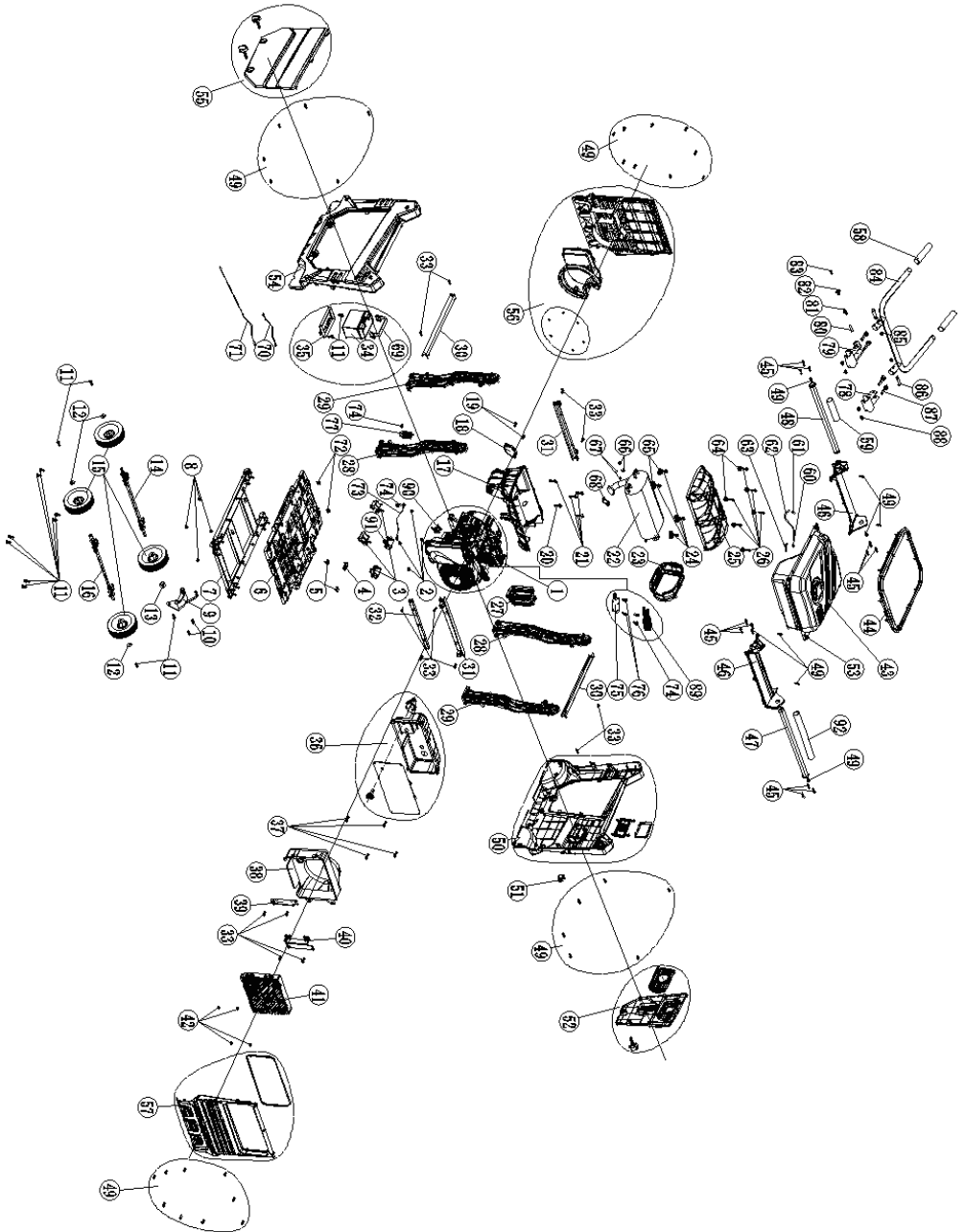

# PARTS LIST

ITEM	ITEM NAME	QTY
1	ENGINE	1
2	Hexagon flange nut	4
3	Damping support	3
4	Plug	1
5	Inverter damping pad	2
6	Base plate assembly	1
7	support/frame seat	1
8	Hexagon flange nut	21
9	Brake parts	1
10	Hexagon flange bolt	2
11	Hexagon flange bolt	18
12	flat washer	5
13	bushing	1
14	Axle	1
15	Wheels assembly	4
16	Axle	1
17	Muffler exhaust lower cover	1
18	Muffler lower cover plate	1
19	Hexagon flange bolt	2
20	Hexagon flange bolt	1
21	Hexagon flange bolt	4
22	Muffler	1
23	Muffler exhaust hood	1
24	Hexagon flange bolt	4
25	Muffler exhaust hood	1
26	Assembly	6
27	Motor exhaust hood	1
28	Bracket/Aluminum	2
29	Bracket/Aluminum	2
30	Rack right beam	2
31	Front and rear upper beam	2
32	Front lower beam	1
33	Hexagon flange bolt	14
34	Battery	1
35	Battery box	1

ITEM	ITEM NAME	QTY
36	Control panel assembly	1
37	Hexagon flange bolt	4
38	Air guide hood assembly	1
39	Inverter left bracket	1
40	Inverter right bracket	1
41	Inverter	1
42	Hexagon flange nut	5
43	Fuel tank assembly	1
44	Fuel tank sealing strip	1
45	Self-tapping screw	12
46	Upper cover assembly	2
47	Handle tube assembly	1
48	Handle tube assembly	1
49	Hexagon flange bolt	39
50	Hexagon flange bolt	1
51	Plug	1
52	Right window panel assembly	1
53	Hexagon flange bolt	1
54	Left side panel assembly	1
55	Left window panel assembly	1
56	Motor cover plate assembly	1
57	Inverter cover plate	1
58	Handle rubber sleeve	2
59	Handle rubber sleeve	1
60	Clamp	1
61	Clamp	2
62	Fuel pipe	1
63	Filter net assembly	1
64	Flat washer	10
65	Flat washer	4
66	Hexagon nut	2
67	Spring washer	2
68	muffler gasket	2
69	Battery strap	1
70	Harness parts/ Negative Charging cable	1



