

Introduction.

This ATS is designed to work with the Excel Power XLD9500Q diesel generator. When the mains power is lost the ATS will start the generator and automatically transfer the load to the generator supply. When mains power is restored the ATS will transfer the load back and shut the generator down.

The unit uses a single-chip microcomputer as the control core and uses digital technology to conduct comprehensive management and monitoring of the unit's status to automate the whole process.

Installation.

This unit is intended for installation by a qualified and competent person and requires installation testing and certification.

Ensure the unit is installed to the correct regulations and the control cable is installed between the generator and ATS panel.

Automatic gear setting

(1) Switch to the "AUTO" position, the panel "AUTO" indicator will illuminate, this means the ATS control system is in the 'mains sensing' state.

(2) Operation of ATS - When the ATS system enters the mains sensing state if the mains power is lost the ATS automatically starts the generator within 2 seconds. After the generator warms up normally for 5 seconds, the system automatically switches the load to the generator power supply.

(3) ATS starts three times - When the generator has poor starting performance due to low temperature or other reasons, the ATS control system will execute three cycles to start, and the starting procedure is as follows:

Mains power failure → the first start time of the generator is 5 seconds → unsuccessful start → stop for 5 seconds → the second start time is 5 seconds → unsuccessful start and stop for 5 seconds → the third start time is 5 seconds (if three times one of the generators can start normally, and the warning light "FAILURE" illuminates.

(4) The generator is automatically stopped – When running and on load, when the mains power returns the generator will run for around 5 to 10 seconds before the ATS control system automatically switches the load back to mains power, and the generator will stop after running for 5 seconds under no-load conditions to cool down.

If in doubt – consult a qualified electrician!

Battery maintenance:

This ATS is equipped with a constant current and floating charging device for the battery.

When there is mains power (voltage 110 ~ 250V), the internal battery charger will charge the battery with constant current (charging current 1A). When the battery is fully charged, the charger changes from constant current charging to floating charging to compensate for the loss of internal charge of the battery and ensure that the battery has sufficient charge start the unit at any time.

Schematic diagram of ATS access power system:

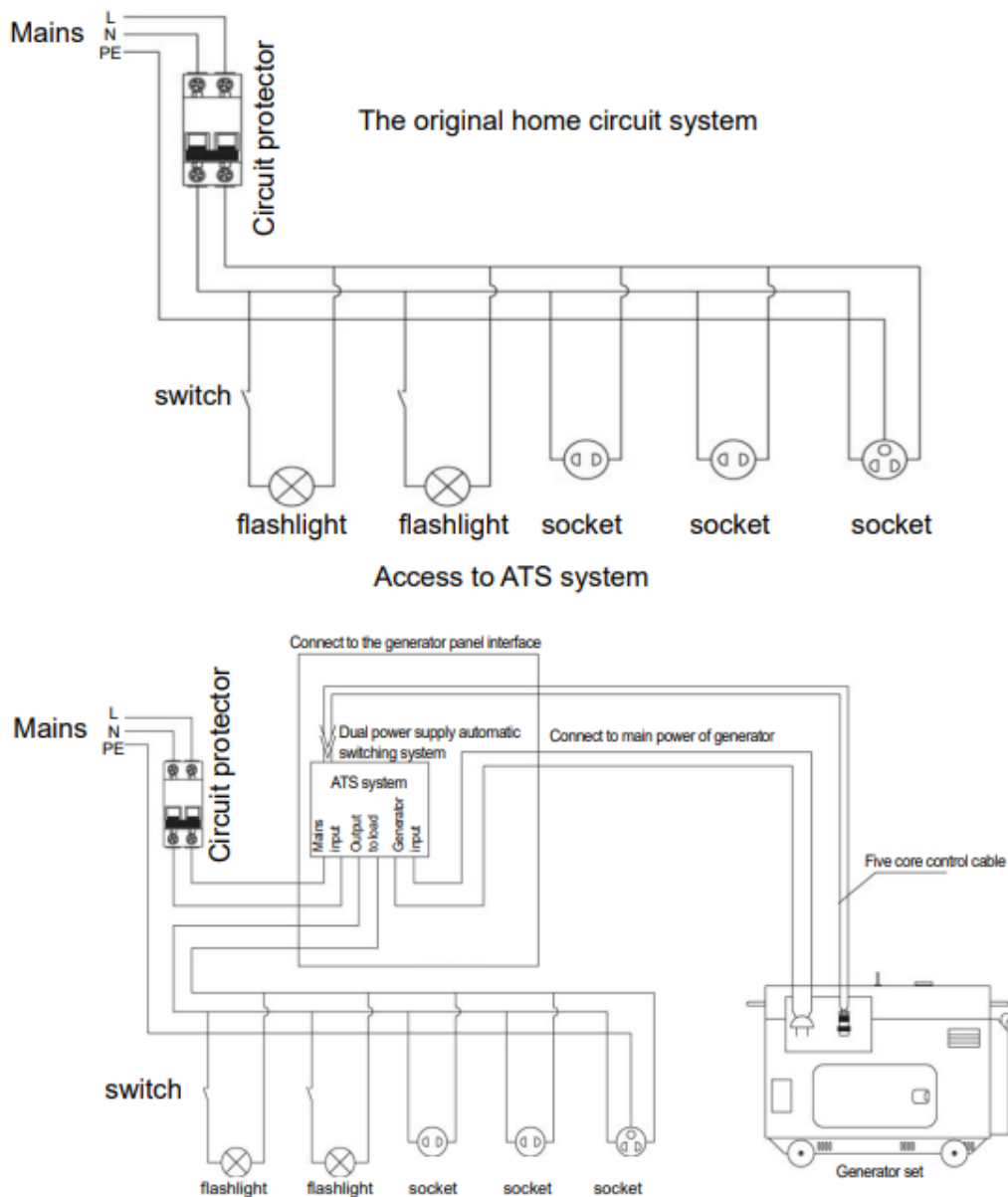

If in doubt – consult a qualified electrician!

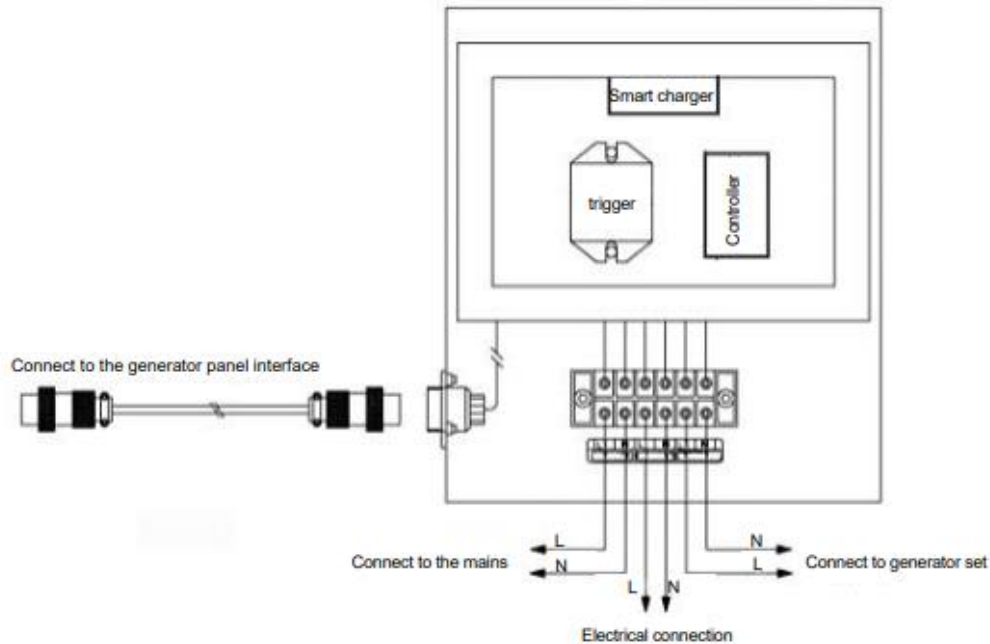
ATS wiring diagram:
1. Single-phase, single-voltage wiring diagram:

Technical parameters:

Working voltage	DC 8~18V (over 20V overvoltage protection)
Contactor rated current	Single phase: 220V/25A (5KW unit) Single phase: 220V/50A (10KW unit) Three-phase: 380V/25A (5~10KW unit)
Internal charger	Input voltage: AC 110~250V Output voltage: DC 13.8V (±2%) Charging current: 1A

Dimensions (mm)	250×140×320
Cable connection line	6-core chrome plated/diesel;8-core chrome/gasoline
The length of the external connection line	1.5m standard (can be customized according to customer requirements)
Working temperature	(-25~60) °C
Storage conditions	(-15~55) °C
Internal wire diameter	2.5mm ² (single-phase, three-phase 5KW unit) 4mm ² (three-phase 10KW unit) 6mm ² (single-phase 10KW unit)

If in doubt – consult a qualified electrician!

Precautions

1. When choosing an ATS always ensure you have the correct rating.
2. Do not directly connect the ATS output to the mains.
3. When the mains power is connected to the ATS, an isolation switch must be used to ensure safety.
4. Please the unit is used mainly in the Automatic configuration and not left in 'Manual' mode.
5. Pay attention to the air switch on the generator panel to the "ON" position.
6. In the ATS working state, it is strictly prohibited to disconnect the battery after the unit is started.
7. The equipment must be placed in a ventilated, dry place, away from high temperatures, high humidity, or vibration.
8. There is high voltage inside the ATS. If a fault occurs, it must be checked by a qualified electrical maintenance person. Ordinary users should not open the case to prevent electric shock.

If in doubt – consult a qualified electrician!