



The FuelHub Compact double wall tank range has been designed for the safe and secure storage and transfer of various industrial lubricants and hazardous liquids world wide.



Available Sizes

- ✓ FHC-1000L / 264G (Transportable)
- ✓ FHC-2050L / 541G (Transportable)
- ✓ FHC-3000L / 793G (Transportable)
- ✓ FHC-4300L / 1136G (Stationary)
- ✓ FHC-6300L / 1644G (Stationary)
- ✓ FHC-8400L / 2219G (Stationary)
- ✓ FHC-10600L / 2800G (Stationary)

FuelHub
compact



Enhanced Design Features

Portable & Static

The FuelHub Compact range, from 1000L to 10600L is guaranteed for the safe and secure storage of fuels & lubricants, and should only be lifted when empty. The FuelHub Compact range from 1000L to 3000L are transportable tanks & 4300L to 10600L are stationary tanks.

Unique Design Standard

The FuelHub double wall tanks are designed with an integral secondary containment tank, and therefore do not require independent bunds for leak containment. This innovative design feature gives access to an extra-large equipment compartment area on all FuelHub Compact tanks.

Maintenance

This design ensures a fast, easy and convenient installation in any location, indoors or out.

Durability

The Cube-style tank design allows for 360-degree tank viewing and inspection. A high-grade paint finish ensures longer durability when exposed to the elements.



Design Innovation

Take a look inside

The FuelHub compact tank range has been designed with Bi-directional forklift pockets for ease of manouveravblity on site. It comes with four stacking corners which also act as lifting devices.

There are conveniently positioned ports & fittings with a recessed equipment compartment area for the upfitting of various 12V Diesel electrical pumps. The tank range is ideal for quick connection to Generators and Pump sets.

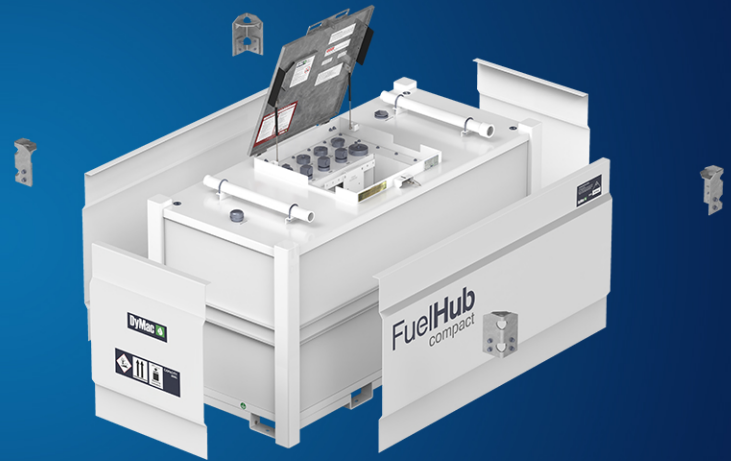

Standard Features



Automatic Desipensing Nozzle with 4M or 8ft hose and various electric pump size options.



Galvanized stacking corner doubles up as a lifting bracket.



2 inch hot galvanized breather pipe

FuelHub compact

Model (FHC-1000L/264G)

The FuelHub Compact FHC-1000L is designed for the safe and secure storage of various industrial lubricants and hazardous liquids worldwide.



Specifications

	Metric	US	Imperial
Capacity	1073 Litres	283 Gallons	236 Gallons
Length	1370 mm	4ft	4ft
Width	1085 mm	3ft	3ft
Height	1270 mm	4ft	4ft
Outer Tank Thickness	4 mm	3/16"	3/16"
Inner Tank Thickness	4 mm	3/16"	3/16"
Weight, Tare	613 kg	1351 lbs, 7 oz	1351 lbs, 7oz
Weight, Laden	1442 kg	3179 lbs, 4 oz	3179 lbs, 4 oz
Safe Fuel Fill Level	975 Litres	258 Gallons	214 Gallons

Approvals and Certifications

UK & Europe

- ✓ ULC S601 Compliant Design
- ✓ UL 142 Compliant Design
- ✓ UN 31 A/Y Compliant Design

USA & Canada

- ✓ ULC S601 Compliant Design
- ✓ UL 142 Compliant Design
- ✓ UN 31 A/Y Compliant Design

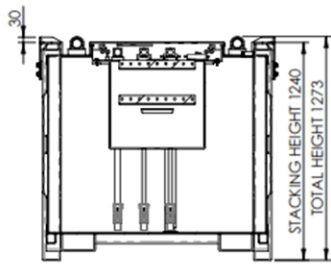

SECTION A-A
SCALE 1 : 30

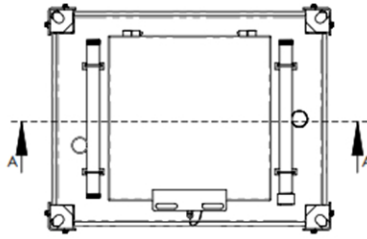

PLAN VIEW

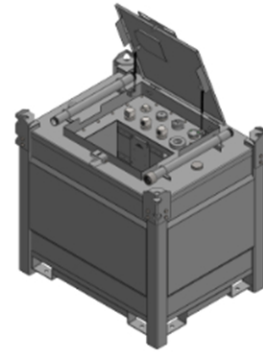

ISOMETRIC VIEW 2

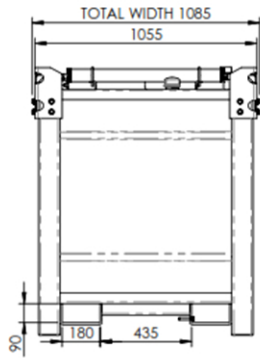

ELEVATION VIEW

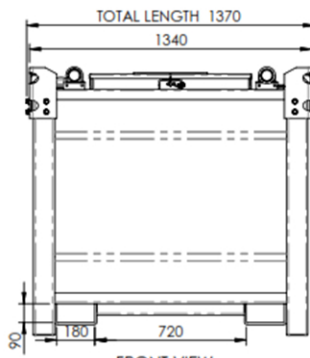

FRONT VIEW

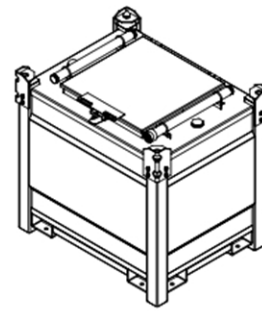

ISOMETRIC VIEW 1

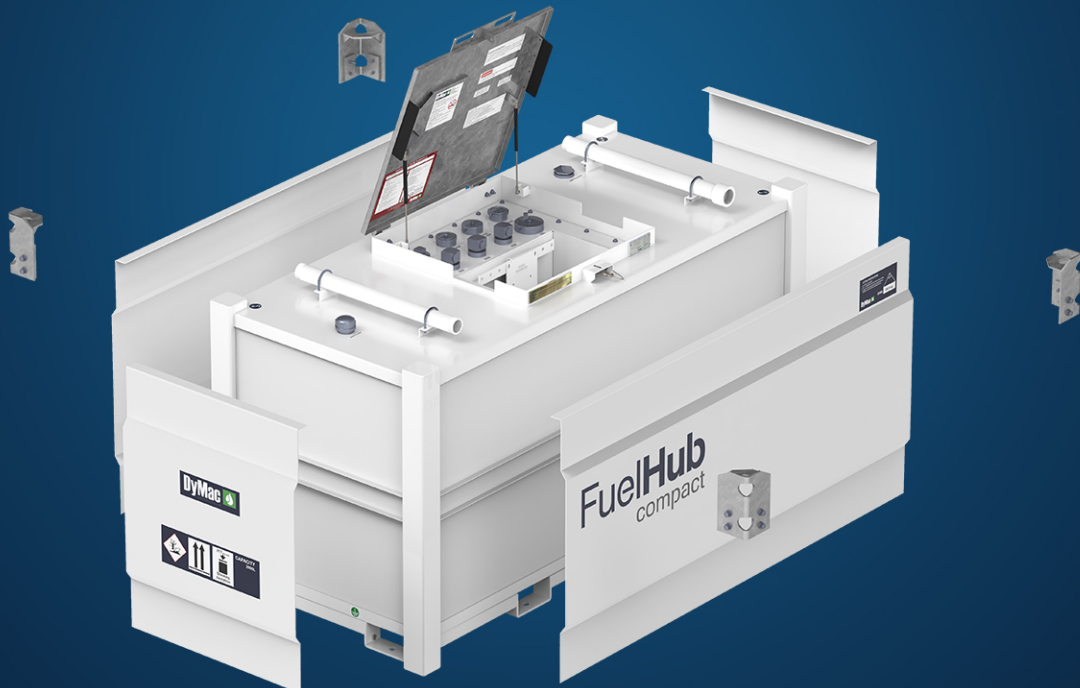

FuelHub compact

Model (FHC-2050L/541G)

The FuelHub Compact FHC-2050L is designed for the safe and secure storage of various industrial lubricants and hazardous liquids worldwide.



Specifications

	Metric	US	Imperial
Capacity	2024 Litres	535 Gallons	445 Gallons
Length	2290 mm	7ft	7ft
Width	1085 mm	3ft	3ft
Height	1270 mm	4ft	4ft
Outer Tank Thickness	4 mm	3/16"	3/16"
Inner Tank Thickness	4 mm	3/16"	3/16"
Weight, Tare	890 kg	1962 lbs, 2 oz	1962 lbs, 2 oz
Weight, Laden	2454 kg	5410 lbs, 2 oz	5410 lbs, 2 oz
Safe Fuel Fill Level	1839 Litres	486 Gallons	401 Gallons

Approvals and Certifications

UK & Europe

- ✓ ULC S601 Compliant Design
- ✓ UL 142 Compliant Design
- ✓ UN 31 A/Y Compliant Design

USA & Canada

- ✓ ULC S601 Compliant Design
- ✓ UL 142 Compliant Design
- ✓ UN 31 A/Y Compliant Design

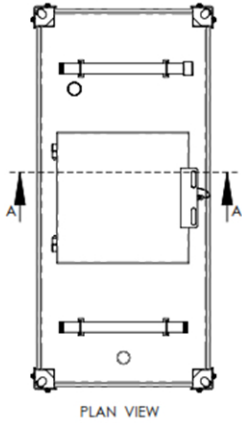

PLAN VIEW

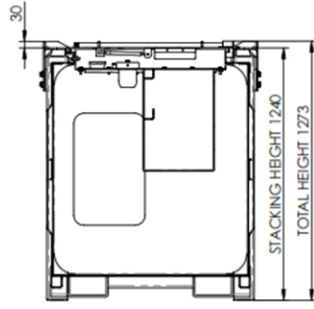

SECTION A-A
SCALE 1 : 25

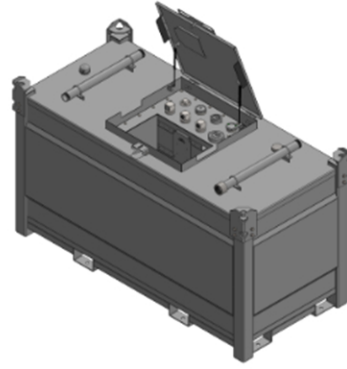

ISOMETRIC VIEW 2

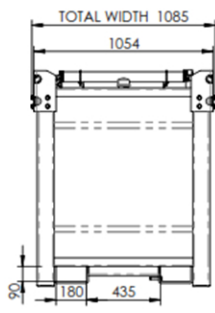

ELEVATION VIEW

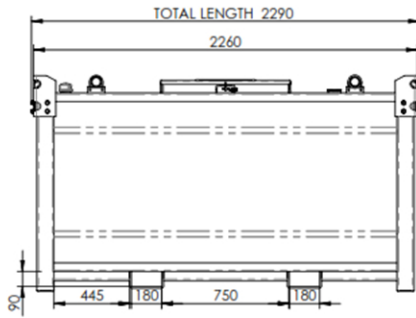

FRONT VIEW

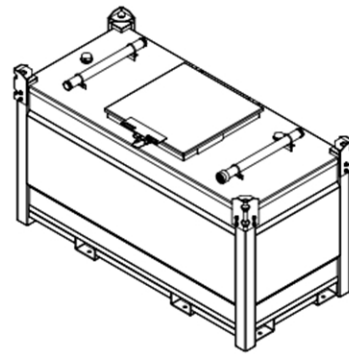

ISOMETRIC VIEW 1

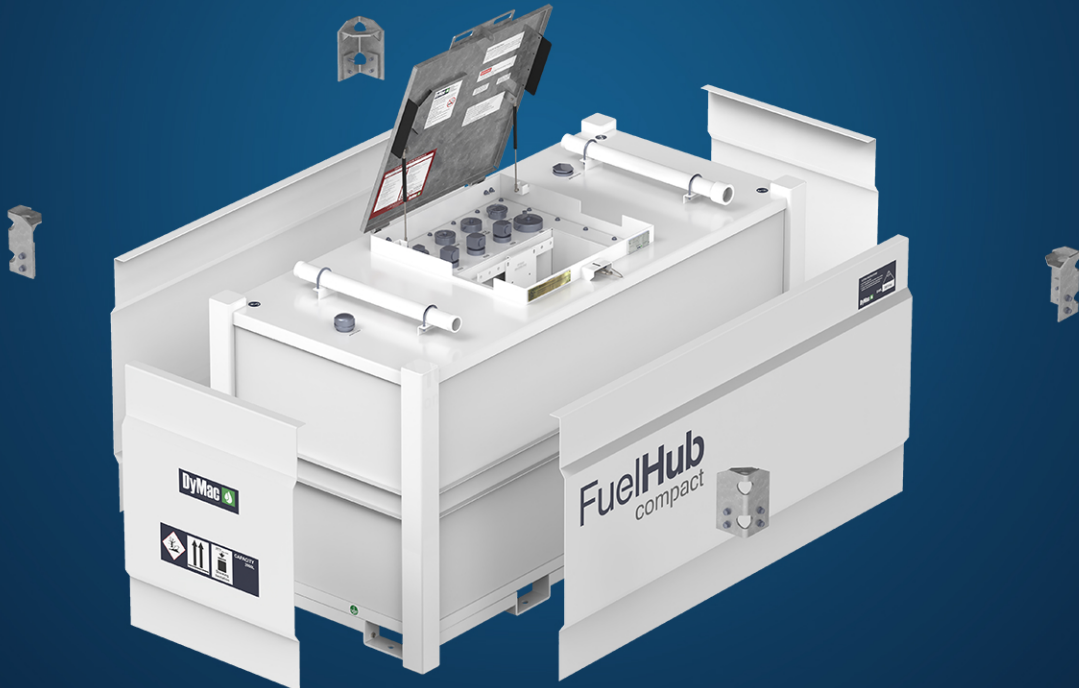

FuelHub compact

Model (FHC-3000L/793G)

The FuelHub Compact FHC-3000L is designed for the safe and secure storage of various industrial lubricants and hazardous liquids worldwide.



Specifications

	Metric	US	Imperial
Capacity	3055 Litres	807 Gallons	672 Gallons
Length	2290 mm	7ft	7ft
Width	1545 mm	5ft	6ft
Height	1270 mm	4ft	4ft
Outer Tank Thickness	4 mm	3/16"	3/16"
Inner Tank Thickness	4 mm	3/16"	3/16"
Weight, Tare	1081 kg	2383 lbs, 3 oz	2383 lbs, 3 oz
Weight, Laden	3441 kg	7586 lbs, 10 oz	7586 lbs, 10 oz
Safe Fuel Fill Level	2777 Litres	734 Gallons	611 Gallons

Approvals and Certifications

UK & Europe

- ✓ ULC S601 Compliant Design
- ✓ UL 142 Compliant Design
- ✓ UN 31 A/Y Compliant Design

USA & Canada

- ✓ ULC S601 Compliant Design
- ✓ UL 142 Compliant Design
- ✓ UN 31 A/Y Compliant Design

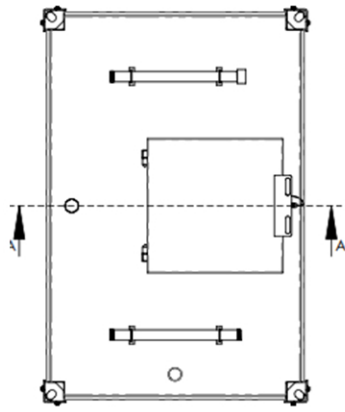

PLAN VIEW

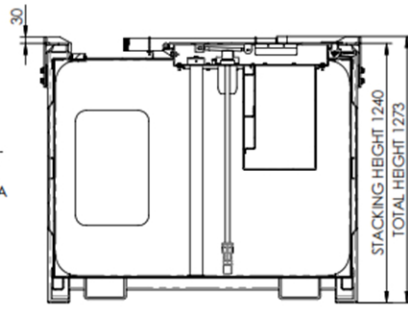

SECTION A-A
SCALE 1 : 25

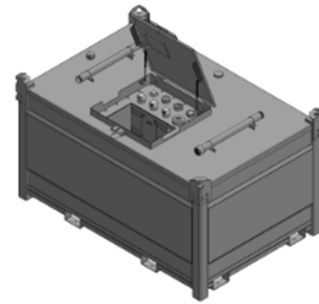

ISOMETRIC VIEW 2

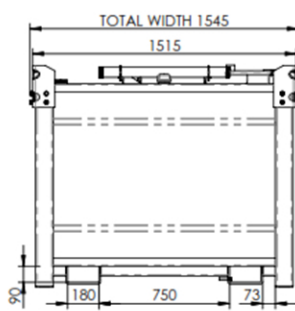

ELEVATION VIEW

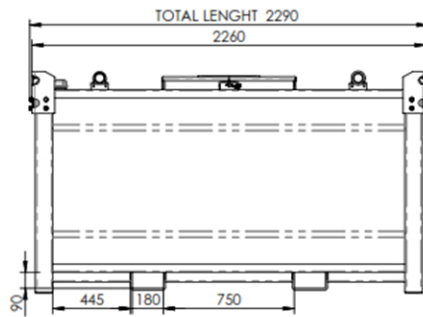

FRONT VIEW

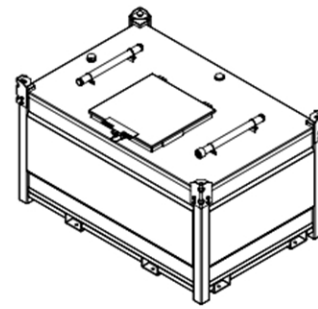

ISOMETRIC VIEW 1

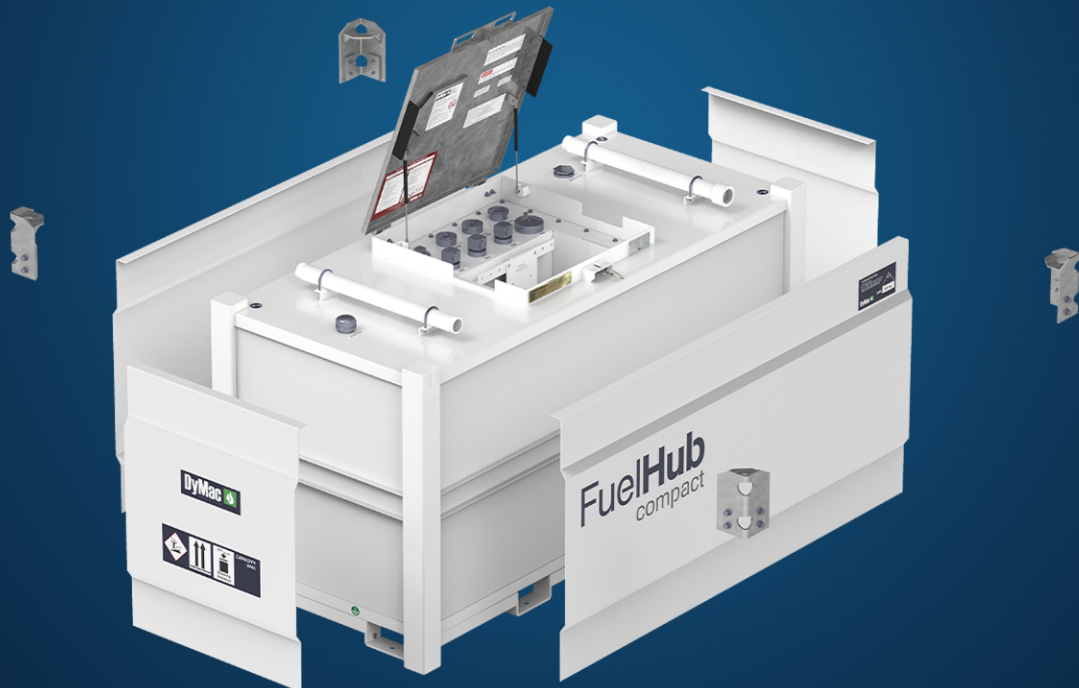

FuelHub compact

Model (FHC-4300L/1136G)

The FuelHub Compact FHC-4300L is designed for the safe and secure storage of various industrial lubricants and hazardous liquids worldwide.



Specifications

	Metric	US	Imperial
Capacity	4264 Litres	1126 Gallons	938 Gallons
Length	2290 mm	7 ft	7 ft
Width	2084 mm	5 ft	5 ft
Height	1270 mm	4 ft	4 ft
Outer Tank Thickness	4 mm	3/16"	3/16"
Inner Tank Thickness	4 mm	3/16"	3/16"
Weight, Tare	1300 kg	2866 lbs, 0 oz	2866 lbs, 0 oz
Weight, Laden	4594 kg	10128 lbs, 1 oz	10128 lbs, 1 oz
Safe Fuel Fill Level	3876 Litres	1024 Gallons	853 Gallons

Approvals and Certifications

UK & Europe

- ✓ ULC S601 Compliant Design
- ✓ UL 142 Compliant Design

USA & Canada

- ✓ ULC S601 Compliant Design
- ✓ UL 142 Compliant Design

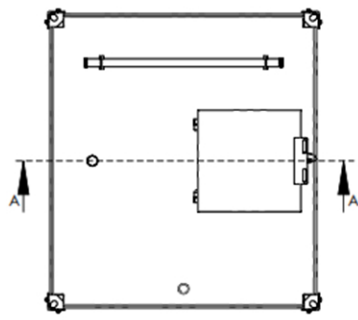

PLAN VIEW

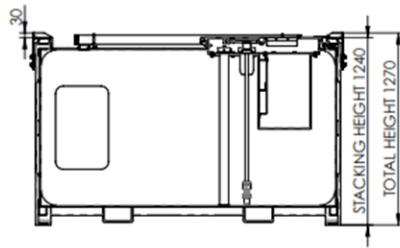

SECTION A-A
SCALE 1 : 35

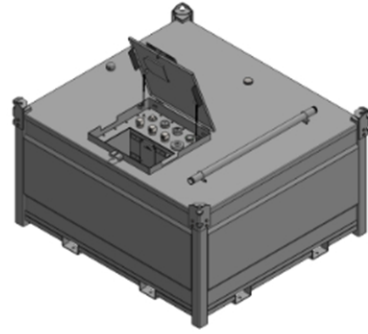

ISOMETRIC VIEW 2

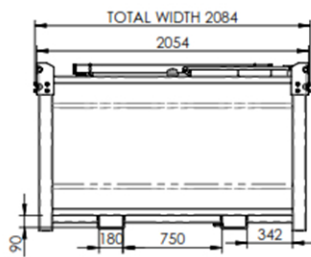

ELEVATION VIEW

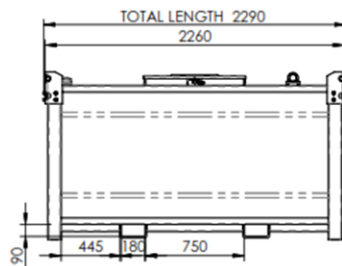

FRONT VIEW

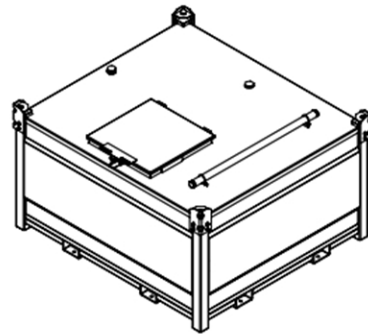

ISOMETRIC VIEW 1

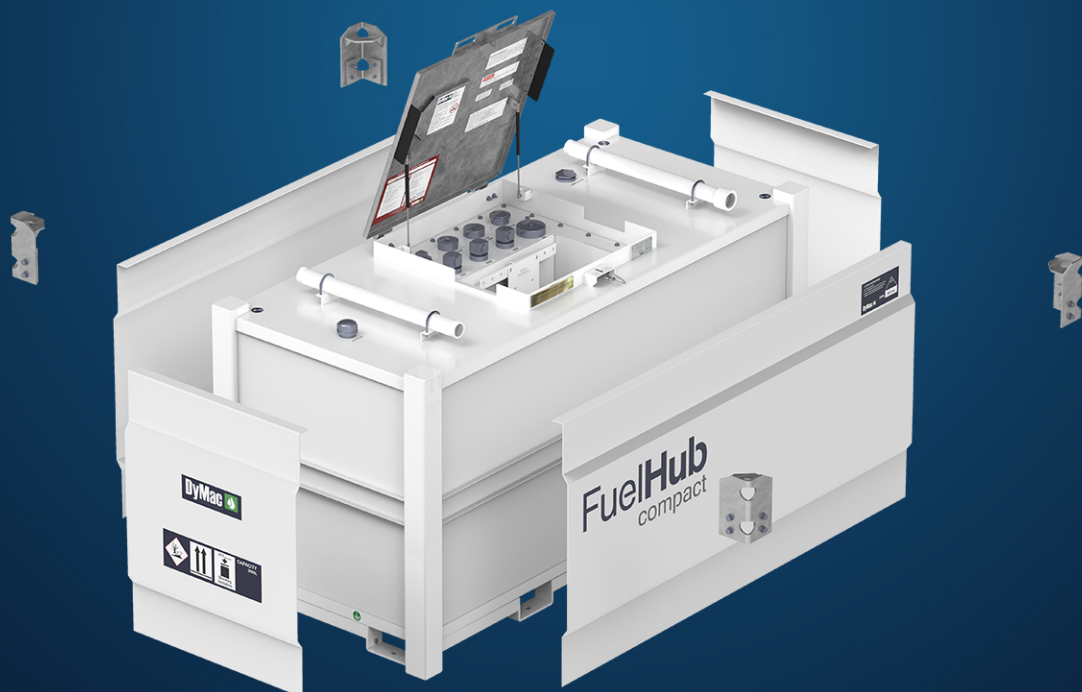

FuelHub compact

Model (FHC-6300L/1644G)

The FuelHub Compact FHC-6300L is designed for the safe and secure storage of various industrial lubricants and hazardous liquids worldwide.



Specifications

	Metric	US	Imperial
Capacity	6215 Litres	1642 Gallons	1367 Gallons
Length	2965 mm	9 ft	9 ft
Width	2294 mm	7 ft	7 ft
Height	1270 mm	4 ft	4 ft
Outer Tank Thickness	4 mm	3/16"	3/16"
Inner Tank Thickness	4 mm	3/16"	3/16"
Weight, Tare	1688 kg	3721 lbs, 6 oz	3721 lbs, 6 oz
Weight, Laden	6518 kg	14369 lbs, 12 oz	14369 lbs, 12 oz
Safe Fuel Fill Level	5682 Litres	1501 Gallons	1250 Gallons

Approvals and Certifications

UK & Europe

- ✓ ULC S601 Compliant Design
- ✓ UL 142 Compliant Design

USA & Canada

- ✓ ULC S601 Compliant Design
- ✓ UL 142 Compliant Design

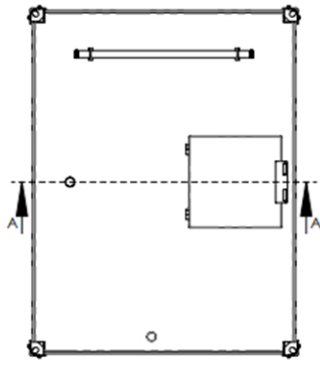

PLAN VIEW

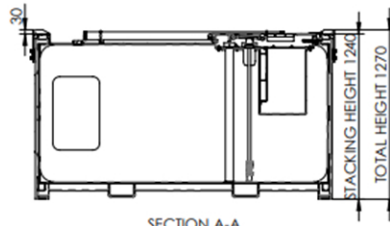

SECTION A-A
SCALE 1 : 40

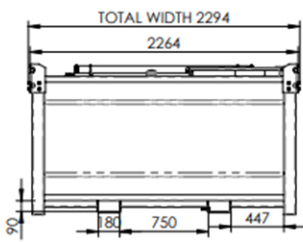
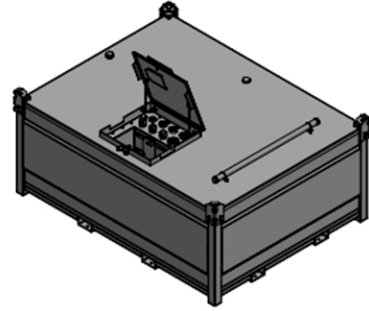

ELEVATION VIEW

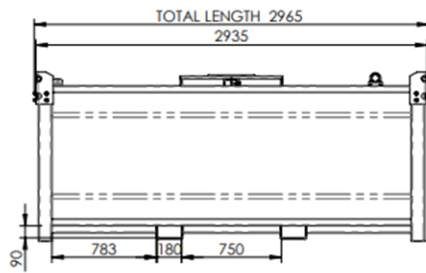

FRONT VIEW

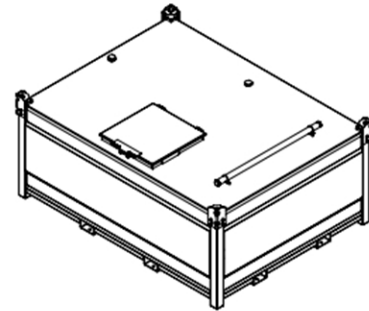

ISOMETRIC VIEW

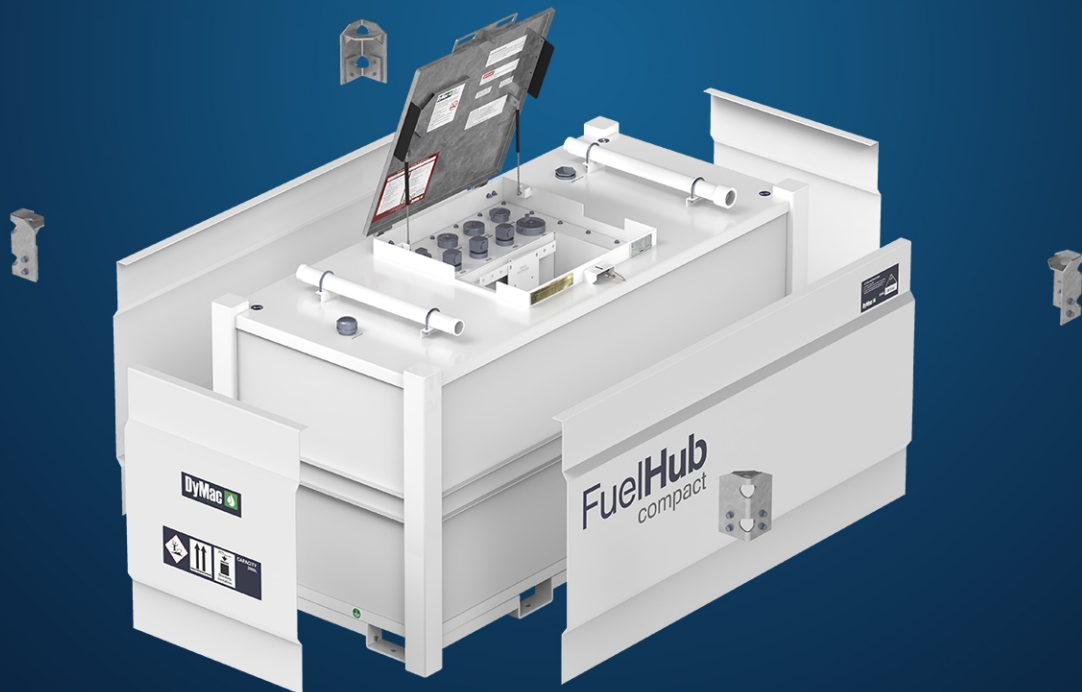

FuelHub compact

Model (FHC-8400L/2219G)

The FuelHub Compact FHC-8400L is designed for the safe and secure storage of various industrial lubricants and hazardous liquids worldwide.



Specifications

	Metric	US	Imperial
Capacity	8389 Litres	2216 Gallons	1845 Gallons
Length	3916 mm	12 ft	12 ft
Width	2294 mm	7 ft	7 ft
Height	1270 mm	4 ft	4 ft
Outer Tank Thickness	4 mm	3/16"	3/16"
Inner Tank Thickness	4 mm	3/16"	3/16"
Weight, Tare	2064 kg	4550 lbs, 5 oz	4550 lbs, 5 oz
Weight, Laden	8545 kg	18838 lbs, 8 oz	18838 lbs, 8 oz
Safe Fuel Fill Level	7625 Litres	2014 Gallons	1677 Gallons

Approvals and Certifications

UK & Europe

- ✓ ULC S601 Compliant Design
- ✓ UL 142 Compliant Design

USA & Canada

- ✓ ULC S601 Compliant Design
- ✓ UL 142 Compliant Design

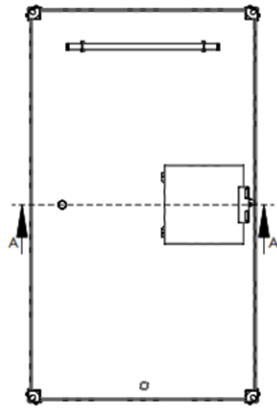

PLAN VIEW

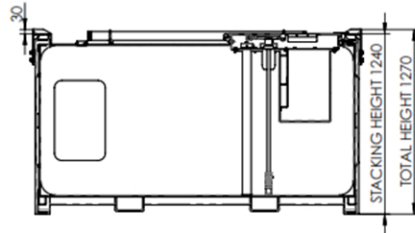

SECTION A-A
SCALE 1 : 35

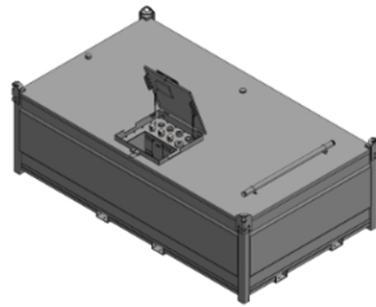

ISOMETRIC VIEW 2

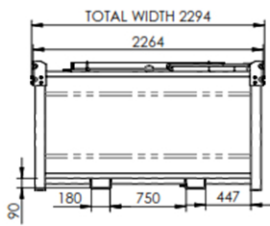

ELEVATION VIEW

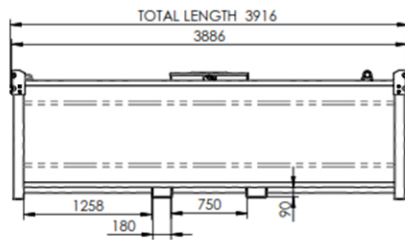

FRONT VIEW

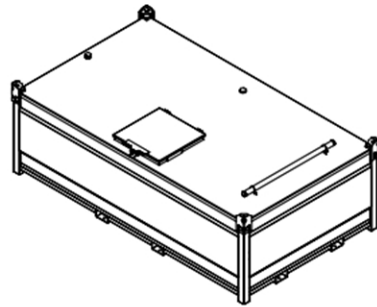

ISOMETRIC VIEW 1

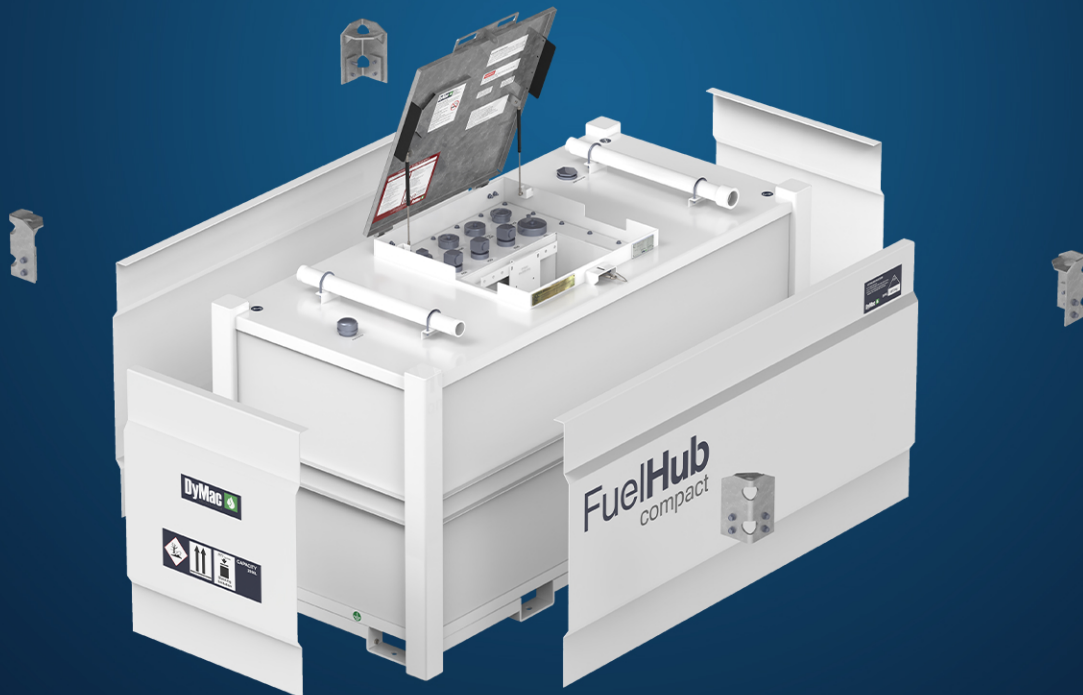

FuelHub compact

Model (FHC-10600L/2800G)

The FuelHub Compact FHC-10600L is designed for the safe and secure storage of various industrial lubricants and hazardous liquids worldwide.



Specifications

	Metric	US	Imperial
Capacity	10544 Litres	2785 Gallons	2319 Gallons
Length	4875 mm	9 ft	9 ft
Width	2294 mm	7 ft	7 ft
Height	1270 mm	4 ft	4 ft
Outer Tank Thickness	4 mm	3/16"	3/16"
Inner Tank Thickness	4 mm	3/16"	3/16"
Weight, Tare	2478 kg	5463 lbs, 1 oz	5463 lbs, 1 oz
Weight, Laden	10625 kg	23424 lbs, 2 oz	23424 lbs, 2 oz
Safe Fuel Fill Level	9584 Litres	2532 Gallons	2108 Gallons

Approvals and Certifications

UK & Europe

- ✓ ULC S601 Compliant Design
- ✓ UL 142 Compliant Design

USA & Canada

- ✓ ULC S601 Compliant Design
- ✓ UL 142 Compliant Design

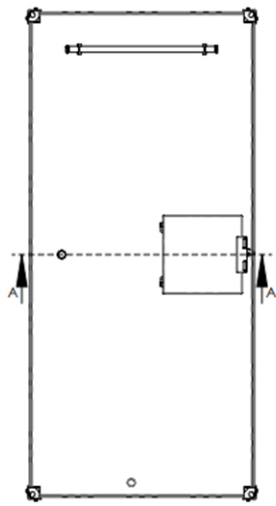

PLAN VIEW

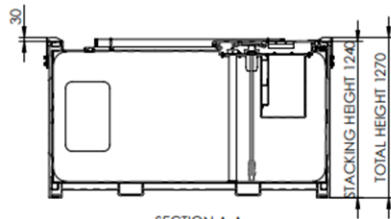

SECTION A-A
SCALE 1 : 40

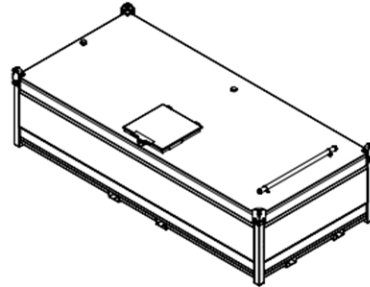
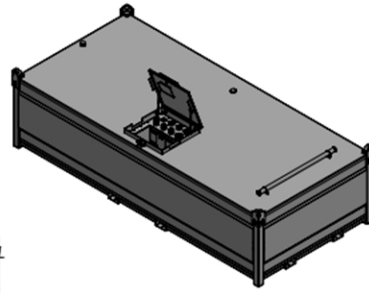

ISOMETRIC VIEW

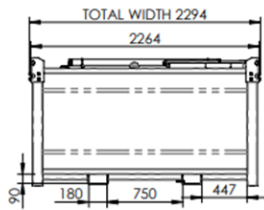

ELEVATION VIEW

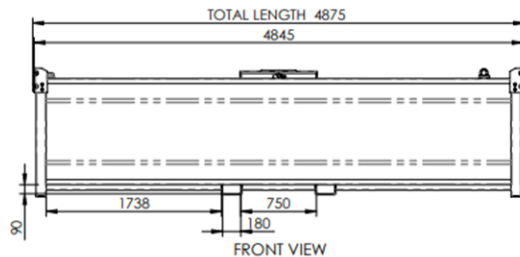

FRONT VIEW

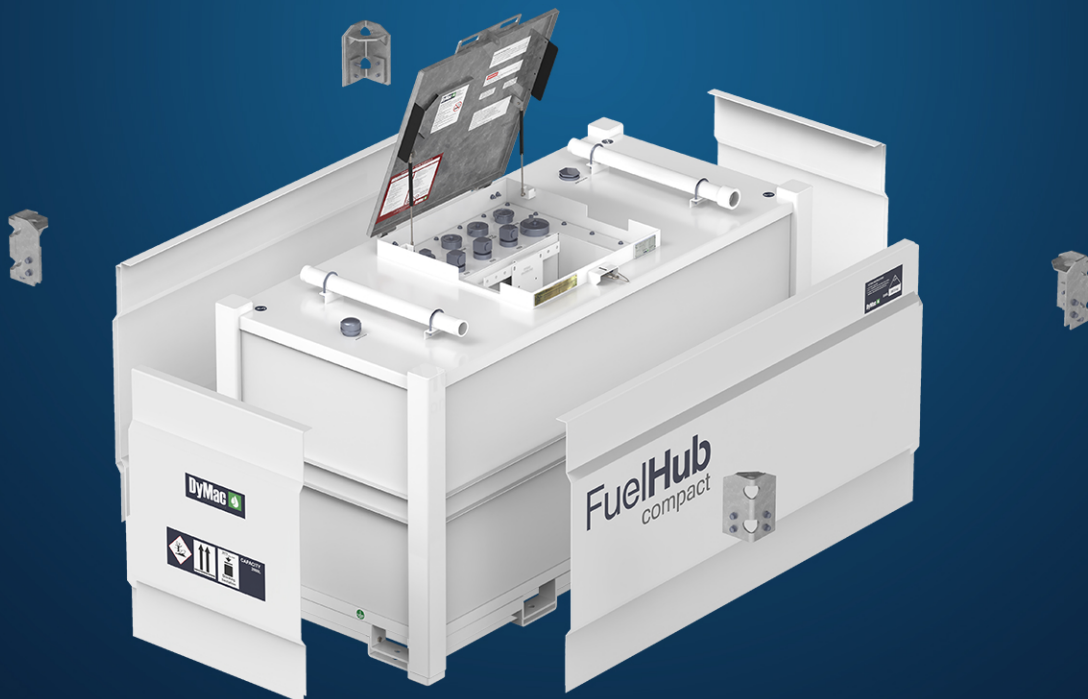



Fuelling Your Progress

DYMAC GLOBAL LTD.

E: sales@dymacglobal.com

T: +353 1 442 0516

BROWNSTOWN ROAD
COMMONS, NEWCASTLE
CO. DUBLIN
IRELAND
D22 Y2F2

DYMAC UK

E: sales@dymacuk.com

T: +44 300 303 3353

SNARESTONE ROAD
NEWTON BURGOLAND
LEICESTERSHIRE
UNITED KINGDOM
LE67 2SN

DYMAC INDIA ENGINEERING PVT LTD.

E: india@dymacglobal.com

T: +91 7349274812

2-18-1557/19,20,21,
AJANTA BUSINESS CENTRE
BEJAI KAPIKAD, MANGALORE
DAKSHINA KANNADA-575004
KARNATAKA, INDIA

DYMAC CANADA INC

E: sales@dymaccanada.com

T: +1 905 564 3654

444 SEAMAN STREET
STONE CREEK
HAMILTON
CANADA
ON L8E 2V9

DYMAC USA INC

E: sales@dymactanks.com

T: +1-240-583-1240

3028 GREENMOUNT AVE #2038
BALTIMORE, MD
UNITED STATES
21218