

# Microinverter Quick Installation Guide\_EN



## Microinverter Installation

### DANGER

- Only qualified personnel should install, troubleshoot, or replace microinverters or the cable and accessories.
- Check any damage caused by transportation. Contact your local distributor or regional sales representative if you find any abnormal conditions.
- Be aware that installation of this equipment includes risk of electric shock. Unauthorized removal of necessary protections, improper use, incorrect installation and operation may lead to serious safety and shock hazards or equipment damage.

## Step 1. Make an installation map

### CAUTION

- If more than one installation site, please mark the installation map individually.
- The installation map represents the PV module arrays

Take out the SN labels and installation map from the package. Paste the SN labels on the installation map as below and complete the information of the solar plant.

Customer: (Name of customer or power station)	Installation Direction: (Direction that the PV modules face to)						Installation Site: (If there are other installation sites, Use different installation map and give them different Map No.)				
	1	2	3	4	5	6	7	8	9	10	11
A											
B											
C											

## Step 2. Mount the microinverter

### WARNING

- When choosing the position of installation,
- Avoid direct sunlight, overheating environment, flammable and explosive substances, electromagnetic device.
  - Please use your mobile phone to check the WiFi signal strength near the installation spot within 1m. If the WiFi signal is less than two bars, please change another installation spot or moving the WiFi router.
  - Make sure good air ventilation. Suggest at least 5cm space gap between roof and microinverter.

### CAUTION

- No screws and nuts in the package.
- The distance between each microinverters should meet the length of AC cables. The length of AC cables are shown as below:

PV Input	Cable Length
Microinverter(4 PV Inputs)	2.52 m
Microinverter(2 PV Inputs)	2.43 m
Microinverter(1 PV Inputs)	1.45 m

Using two pairs of screws and nuts to mount the microinverter on the frame. Mount the microinverter's flat surface up.

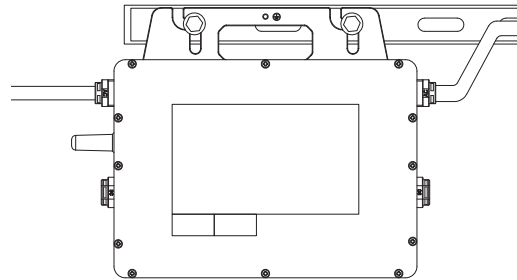

## Step 3. Connect the ground cable

### WARNING

- Ensure that all microinverters are well grounded.
- Use  $\phi 6$  screw for the ground port.

Connect the ground cable to the ground port.

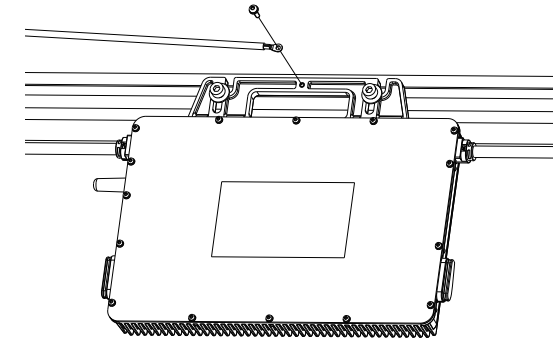

## Step 4. Connect the AC cable between two microinverters

### WARNING

Max. installation quantity for the microinverter in each string is based on the max. current of the AC cable.

Quantities for each string

Output Power[W]	300	350	400	450	500	600	700	800	900	1000	1600	1800	2000
Max. Units Per Branch(12AWG)	23	19	17	15	13	11	9	8	7	6	4	3	3
Max. Units Per Branch(10AWG)	30	26	23	20	18	15	13	11	10	9	5	5	4

Connect the AC cable between two microinverters.

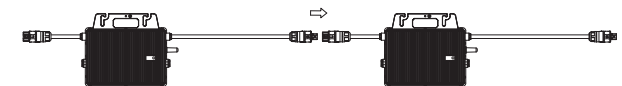

Use Nylon cable ties to fasten the AC cables onto the frame.

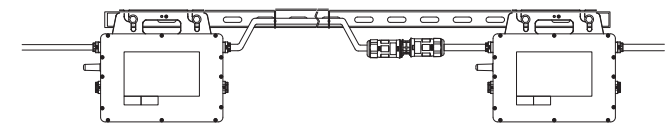

Attach the protection cap to the terminal AC connector of each string.

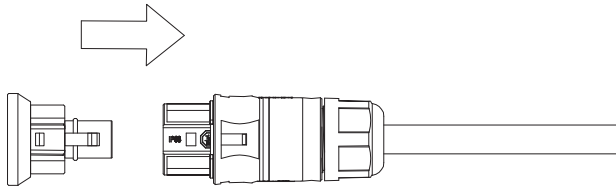

### Step 5. Connect AC end cable

<b>DANGER</b>
· Cut off AC breaker before installation.
<b>WARNING</b>
· Ensure that all AC cables are correctly wired and not pinched or damaged. · Use AWG 12 (4 mm <sup>2</sup> ) cable for AC end cable
<b>CAUTION</b>
· The installation technician is responsible for selecting a proper AC cable and connecting the microinverter system into the home power grid correctly. · The AC connectors may be provided by different suppliers. The port definitions are subject to actual objects. · The AC connector and protection cap should be purchased additionally.

Disassemble the AC connector as shown below.

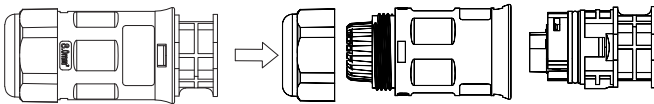

Get the AC cable through the shell of AC connector and connect the cable to the right port.

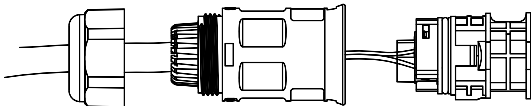

The definition of each port is shown below:



L: Live	_____	(Brown/Red)
N/L: Neutral/Live	_____	(Blue/Black)
PE: Ground	_____	(Yellow-Green)

Reassemble the AC connector. Plug it into the microinverter and connect the other end to the AC distribution box.

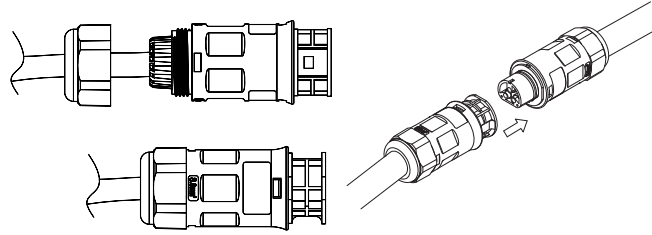

### Step 6. Connect DC cable

<b>DANGER</b>
· When the photovoltaic array is exposed to light, it supplies a DC voltage to the microinverter.
<b>WARNING</b>
· Ensure that all DC cables are correctly wired and not pinched or damaged. · The DC conductors of this photovoltaic system are ungrounded and may be energized. · The max. open circuit voltage of the PV module must not exceed the specified max. input DC voltage of the microinverter
<b>CAUTION</b>
· Use a DC extension cable if the DC cable is too short for installation. · Use MC4 compatible DC connectors on the inverter side of DC extension cable. · Contact PV module manufacturers for the requirements of DC connectors on the module side of DC extension cable.

Install the PV modules and connect the DC cable to the microinverter.

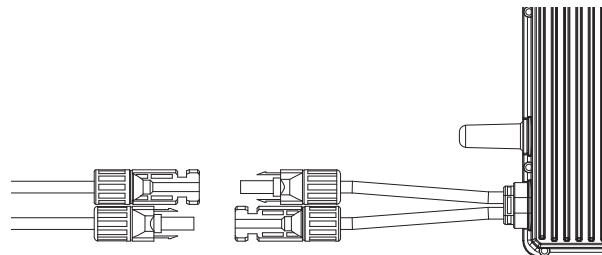

### Step 7. Start the system

<b>DANGER</b>
· Only qualified personnel should connect this system to the power grid.
<b>CAUTION</b>
· Complete all the installation procedures and get approval from the electrical utility company before connecting microinverters to the grid

Turn on the main utility-grid AC circuit breaker. Your system will start to produce power after about a two-minute waiting time.

The definition of LED is shown as below.

Status	Indicates
Flashing Green	Working normally
Flashing Red	Working abnormally
Solid Red	Out of work

After completing the installation, please use the Monitoring User Guide and Monitoring User Manual to download the monitoring platform and register your account.



EU Declaration  
of Conformity  
(DOC)



Full Manual  
Microinverter

TSUNESS Co., Ltd

E-MAIL : sales@tsun-ess.com  
WEB : www.tsun-ess.com  
TEL : +86-512-66186028

